

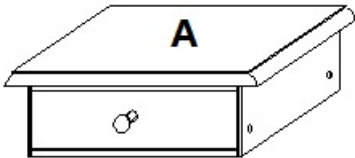

PARTS:

No.	Picture	Description	Quantity
A		Top with Drawer	1 pc
B		Left Side Panel	1 pc
C		Right Side Panel	1 pc
D		Shelf	1 pc





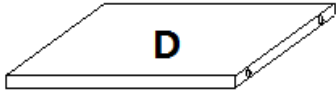

Head Office, 11 Bridge Street,
 Bishop's Stortford CM23 2JU
 Tel: 0844 482 4400*
 Fax: 01279 756 595
www.coopersofstortford.co.uk

Coopers
 OF STORTFORD

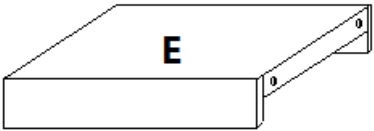
*Calls cost 7 pence per minute plus your telephone company's network access charge

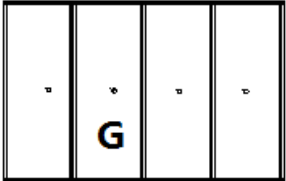
Please read and retain these instructions for future reference

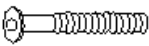
v001: 04/07/19

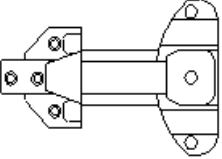
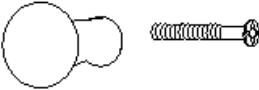
E		Base	1 pc
F		Back Panel	1 pc
G		Door	1 pc
1		Allen Key	1 pc
2		Bolt with Hexagonal Head 6x20mm	8 pcs
3		Wooden Dowel 8x30mm	4 pcs
4		Tapping Screw 3x14mm	16 pcs
5		Hinge	2 pcs
6		Knob with bolt	4 sets

Tool Required: 1x Philips screwdriver (not included)

- 2-person assembly
- Please inspect all parts prior to assembly and contact us if there are any damaged or missing components.

Head Office, 11 Bridge Street,
Bishop's Stortford CM23 2JU
Tel: 0844 482 4400*
Fax: 01279 756 595
www.coopersofstortford.co.uk

Coopers
OF STORTFORD

*Calls cost 7 pence per minute plus your telephone company's network access charge

Please read and retain these instructions for future reference

v001: 04/07/19

Step 1. Please pull out the drawer before assembly

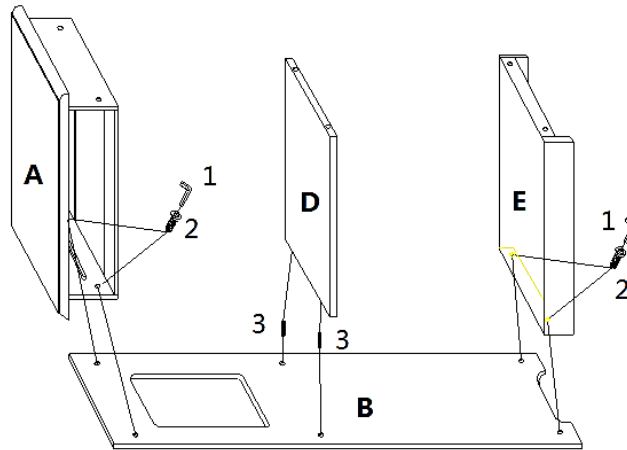

Step 2

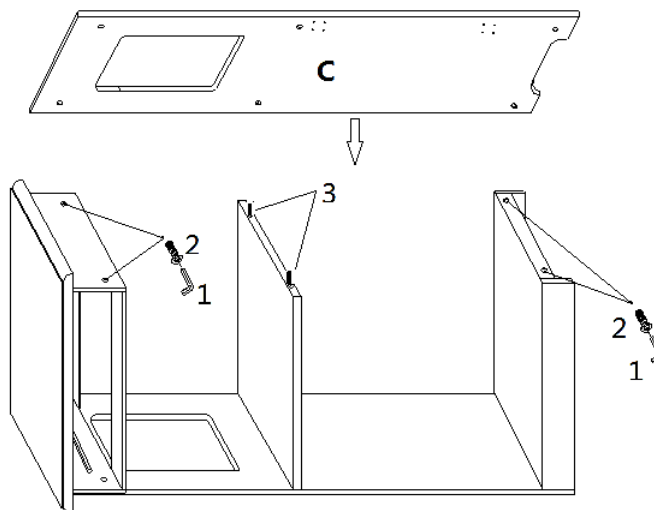

Step 3

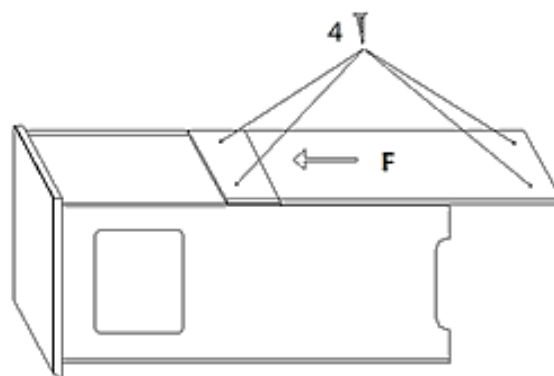

Head Office, 11 Bridge Street,
Bishop's Stortford CM23 2JU
Tel: 0844 482 4400*
Fax: 01279 756 595
www.coopersofstortford.co.uk

Coopers
OF STORTFORD

*Calls cost 7 pence per minute plus your telephone company's network access charge

Please read and retain these instructions for future reference

v001: 04/07/19

Step 4. Please insert the drawer after assembly

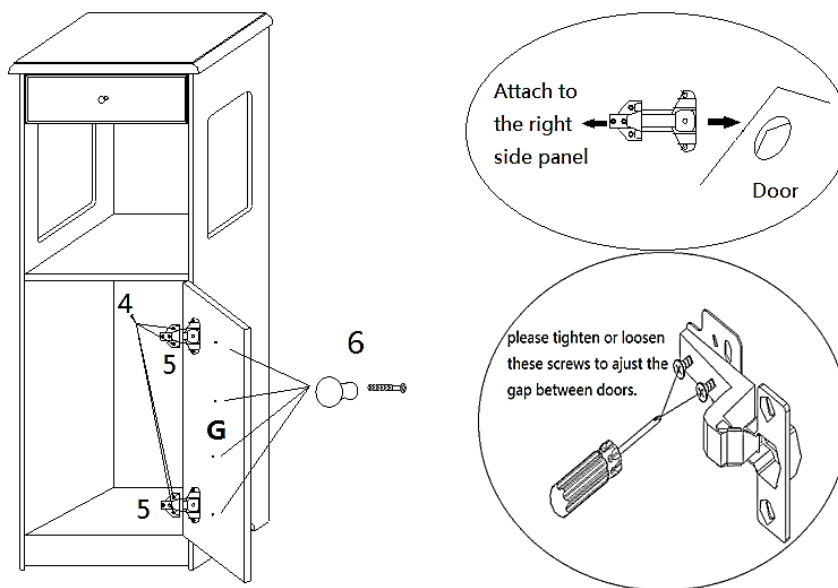

Fully Assembled

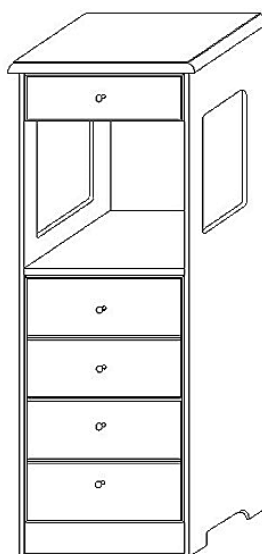

CARE AND CLEANING INSTRUCTIONS:

- Regularly check that all parts remain tight
- Do not exceed maximum weight limit 20kgs
- Do NOT use abrasive cleaners or sharp utensils to clean this product.
- Store the item in a cool, dry place.
- Wipe with a clean dry cloth.

DISPOSAL

- Dispose of all packaging, paper, cartons, plastic and plastic bags in accordance with your local recycling regulations.
- At the end of the product's lifespan please dispose of it at an authorised household waste recycling centre.

Head Office, 11 Bridge Street,
Bishop's Stortford CM23 2JU
Tel: 0844 482 4400*
Fax: 01279 756 595
www.coopersofstortford.co.uk

Coopers
OF STORTFORD

*Calls cost 7 pence per minute plus your telephone company's network access charge