

**Dimensions:**

75cm (L) x 88cm (W) x 108cm (H)

Material:

Polyester

Weight:

39.5kg

Colour

Terracotta

Max weight load: 115kg

This unit is heavy and should only be lifted by 2 persons.

ASSEMBLY INSTRUCTIONS / INSTRUCTIONS FOR USE:

Unpack the components carefully. Please check all parts have been removed from the packaging and locate the chair on a flat, stable surface.

User Instructions

The chair is ready for use once the chair has been fully installed in the correct position and the user has read and understood the user instructions.

Installation

Before moving the chair:

- Ensure that it is switched off at the mains socket.
- Unplug the lead from the transformer to the chair and neatly coil the cable. Place the cable either in the side pocket or on the seat of the chair to ensure it does not become entrapped and damaged in transit.
- Ensure that there is a power socket available close to where the chair will be placed.
- Protect the floor with a blanket or a sheet to avoid scratching.
- The Rise & Recline Chair is heavy. Take extreme care when lifting to avoid personal injury or damage to the product.

Note: Small black particles of powder coating may occasionally rub off the metal action of a riser & recliner chair during use. Protect a pale coloured carpet or floor before positioning the chair.

Dimensions

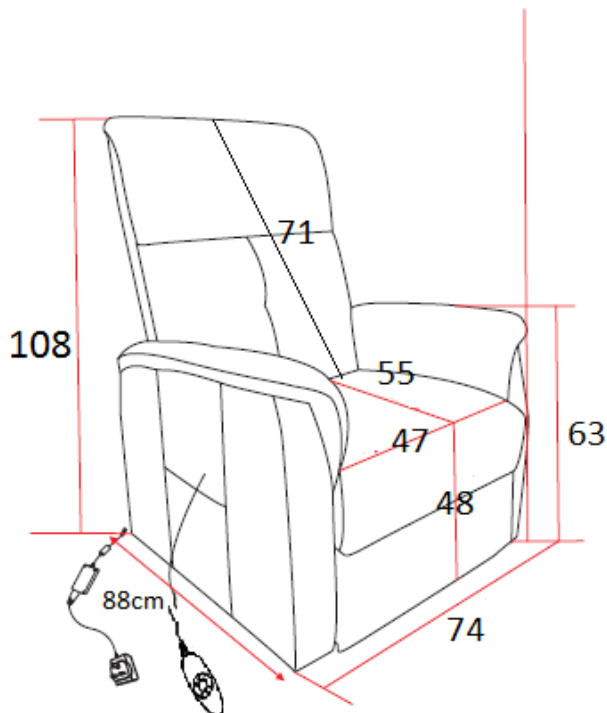

Parts

① Backrest



Locking lever

Power supply

④

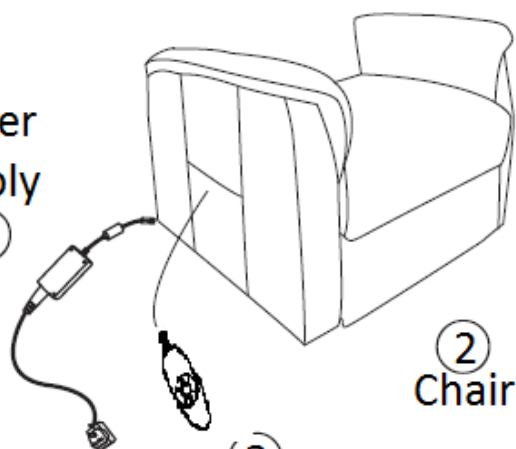

② Chair

③ Remote

Assembly

1.

Do not cut any other plastic ties underneath the chair

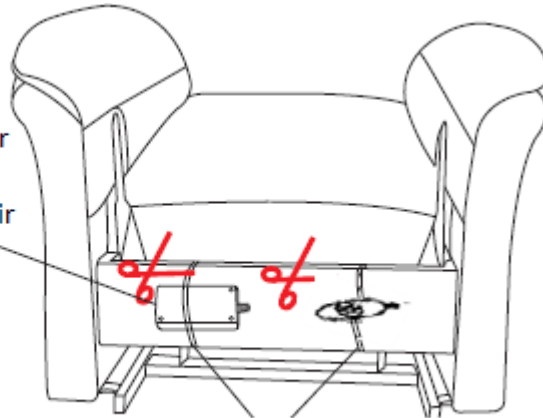

Cut plastic ties here

2

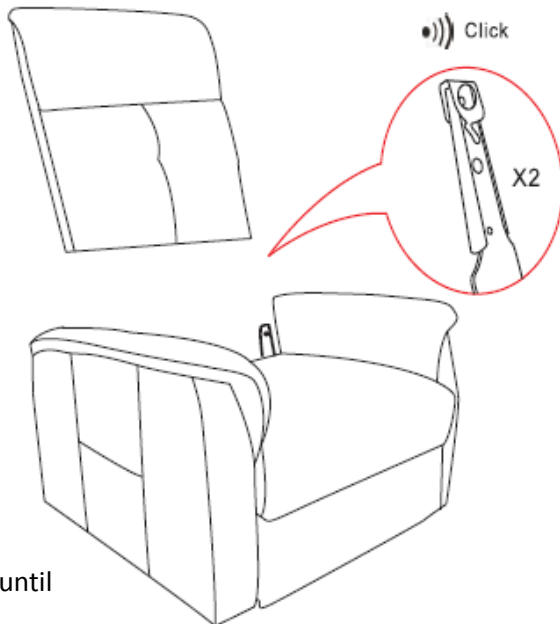

Lock until click

3

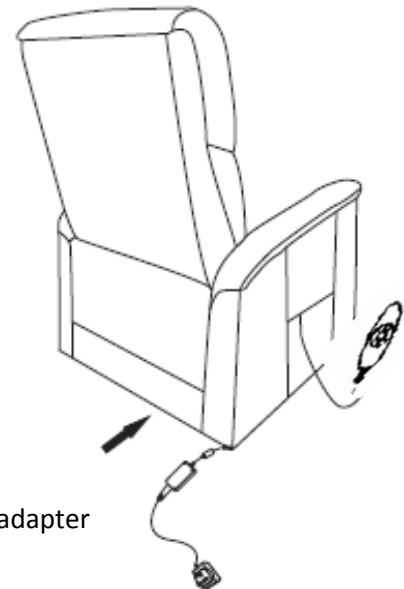

Plug in adapter

If the back of your chair needs to be removed for transit please do the following:-

- Recline the backrest slightly and then release the backrest by pulling the locking levers forward. The locking levers are situated at the rear of the chair between the arm unit and backrest.
- Lift the hook & loop backflap and tuck out of the way to ensure it does not reattach itself.
- Standing behind the chair grasp the backrest at about the point where the backrest meets the arm unit and pull evenly upwards and towards yourself.
- After the chair has been moved replace backrest and ensure that it is locked securely in place by pushing the levers back and reattaching the hook & loop.

Always check that the backrest has been located securely on the metal plates and is level and totally secure before using the chair.

Note: Backrest units are heavy and need to be lifted out evenly to avoid bending the metal plates. Care should be taken not to strain one's back when attempting to remove or refit a backrest.

Rise & Recline Chairs are fitted with a remote transformer block which is attached to a 13 amp plug. The transformer block must not be allowed to dangle from a high socket. Always take care not to trip over the block and keep it located in the safest possible position in a well ventilated, dry place on the floor where it sits on its rubber feet. The transformer reduces the 240V mains power to a safe low voltage of just 24V.

- Connect one end of the extension lead into the matching two prong slot in the transformer block and the other end into the plug situated at the rear of the chair underneath the back flap, usually held fast by a cleat.
- Then connect the mains plug of the transformer into a suitable mains power socket and switch on the power.
- The chair should now operate when the handset buttons are pressed.

It is not recommended to use extension leads with this product but plug the electrical lead directly into the socket.

Operating Instructions

Warning:

- Always ensure that there is nothing to obstruct the free movement of the chair.
- Before first use, the chair should be tested to ensure that all functions are working correctly.
- Exercise care when lowering into the chair.
- Do not sit on the arms.

Safety Cut-out

The motors are not designed for continuous operation. In the even that motors overheat, or the power limit of motors is exceeded, a safety device will cut out the power.

If the chair does not restart after approximately 20 minutes, please contact Customer Services.

Adjusting the chair

Warning:

Take care when adjusting positions to avoid trapping or pinching of body parts.

When the chair is not in use it should be returned to the seated position.

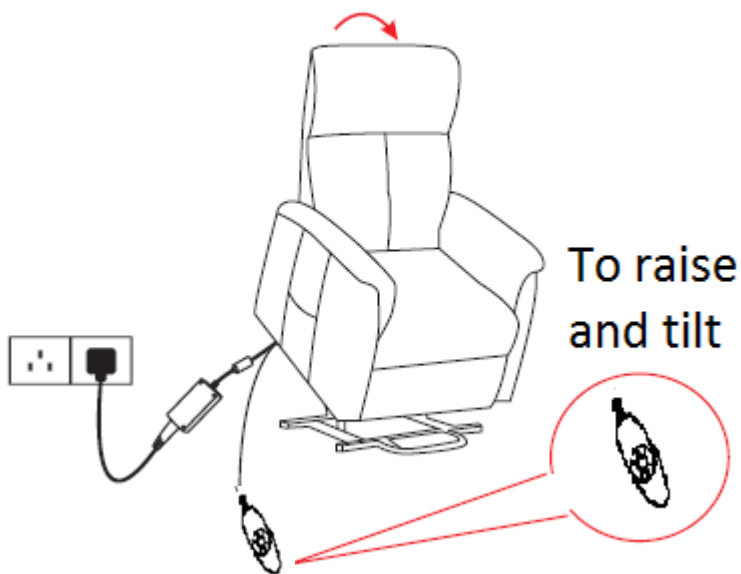
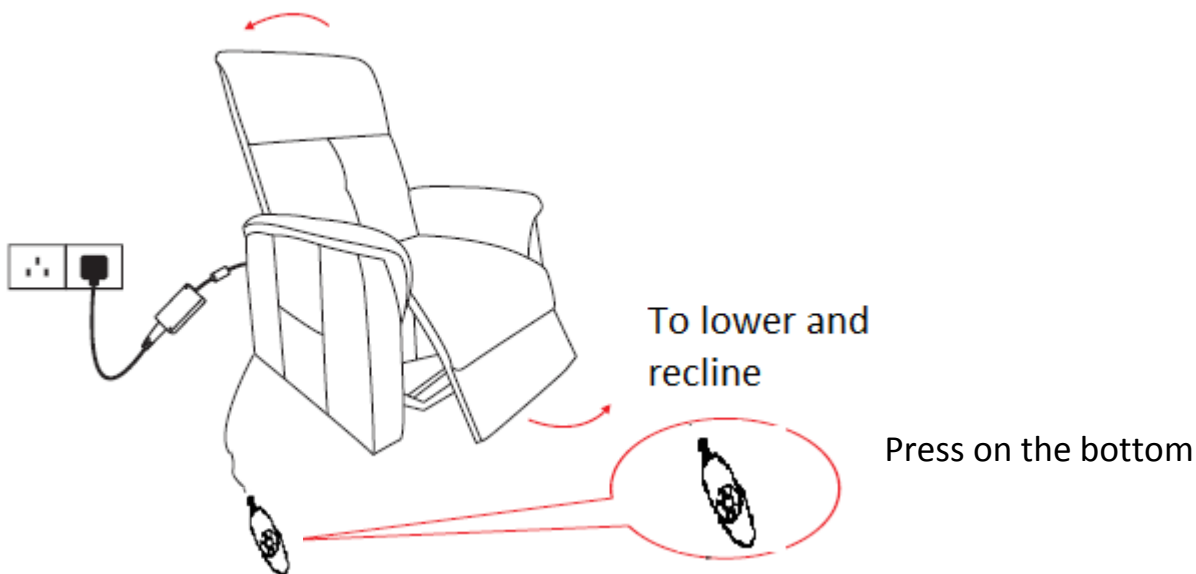

The top button is for lifting, the bottom button is for reclining.

Keep pressing the buttons to adjust the position. Stop pressing the button when desired position is reached.

WARNINGS AND SAFETY INSTRUCTIONS:

WHEN USING ELECTRICAL RECLINING CHAIRS, BASIC SAFETY PRECAUTIONS SHOULD ALWAYS BE FOLLOWED:

- READ ALL INSTRUCTIONS BEFORE USE.
- FOR DOMESTIC INDOOR USE ONLY.
- DO NOT USE OUTDOORS OR FOR COMMERCIAL USE.
- BEFORE USE, CHECK THOROUGHLY FOR ANY DEFECTS AND DO NOT USE IF DEFECTS ARE FOUND. TAKE CARE NOT TO DROP THE RECLINING CHAIR AS HEAVY IMPACTS MAY CAUSE INTERNAL DAMAGE.
- BEFORE CONNECTING THE RECLINING CHAIR, CHECK IF THE VOLTAGE INDICATED ON THE BOTTOM OF THE RECLINING CHAIR IS IN ACCORDANCE WITH THE MAINS VOLTAGE IN YOUR HOME.
- CHECK THE RECLINING CHAIR AND POWER CABLE CAREFULLY FOR DAMAGE BEFORE EACH USE.
- DO NOT LET CHILDREN JUMP OR PLAY ON THIS ELECTRIC RECLINING CHAIR.
- DO NOT STAND ON THIS ELECTRIC RECLINING CHAIR TO AVOID DAMAGE OR INJURY,
- THE USE OF ANY ACCESSORY ATTACHMENTS NOT RECOMMENDED BY COOPERS OF STORTFORD MAY CAUSE INJURIES AND INVALIDATE ANY WARRANTY YOU MAY HAVE.
- DO NOT LET THE POWER CABLE HANG OVER THE EDGE OF A TABLE OR COUNTER, OR TOUCH HOT SURFACES.
- DO NOT PLACE NEAR HEAT SOURCES.
- USE ON A LEVEL, STABLE SURFACE.
- DO NOT USE THIS RECLINING CHAIR FOR ANY OTHER USE THAN THE INTENDED USE IT IS DESIGNED FOR.
- ENSURE THERE IS SUFFICIENT DISTANCE BETWEEN THIS RECLINING CHAIR AND OTHER ITEMS ON THE WORK SURFACE OR WORK STATION, OR SUFFICIENT DISTANCE BETWEEN THE RECLINING CHAIR AND THE CONFINES OF THE AREA IN WHICH IT IS SITUATED. WE RECOMMEND A MINIMUM CLEARANCE AROUND ALL FACES OF AT LEAST 10CM.
- TO PROTECT AGAINST ELECTRIC SHOCK, DO NOT IMMERSE POWER CABLE OR PLUG, IN WATER OR ANY OTHER LIQUID.
- UNPLUG FROM OUTLET WHEN NOT IN USE AND BEFORE CLEANING.
- DO NOT OPERATE ANY RECLINING CHAIR WITH A DAMAGED POWER CABLE OR PLUG OR AFTER THE RECLINING CHAIR MALFUNCTIONS, OR HAS BEEN DAMAGED IN ANY MANNER. WE RECOMMEND THAT THE POWER CABLE IS NOT KINKED OR STORED IN A TWISTED MANNER, AND THAT YOU REGULARLY CHECK ITS CONDITION.
- ANY REPAIRS MUST BE CONDUCTED BY A QUALIFIED ELECTRICIAN OR ELECTRICAL SERVICE AGENT.
- IF THE HANDSET, TRANSFORMER OR ANY OTHER ELECTRICAL COMPONENT BECOME WET, THE CHAIR SHOULD BE UNPLUGGED AT ONCE.

Care and Maintenance

Warning: to ensure safe and reliable operation, the chair should be regularly checked (monthly) by the user. Monthly checks:

- Any damage to the mains power cable
- Any damage to the handset cable
- Full functionality of the controls handset
- Any loose or detached parts
- Any damage to the fabric of the chair and any soiling of the fabrics.

Warning: There are no user serviceable parts.

Head Office, 11 Bridge Street,
Bishop's Stortford CM23 2JU
Tel: 0844 482 4400*
Fax: 01279 756 595
www.coopersofstortford.co.uk

Coopers
OF STORTFORD

Upholstery maintenance

- The chair should be kept clean and dry. It is recommended that the chair is vacuum-cleaned once a week.
- Do not expose to high temperatures or strong sunlight as this could cause the fabric to fade.
- Do not put any heavy objects on the armrests.

- **Warning:** Disconnect the chair from the mains supply before carrying out any cleaning.
- Check the chair for functionality after cleaning the chair.
- Periodically retighten fixings.

PLUG WIRING (UK & IRELAND)

This RECLINING CHAIR is supplied with a mains adaptor/charger with BS1363 plug pins.

DO NOT use if the socket outlets in your home or office are not suitable for this product's mains adaptor/charger plug pins. Attempts to insert the mains adaptor/charger into the wrong socket is likely to cause electric hazard or damage.



DO NOT use with any other mains transformer/charger than the one that is supplied with this product.

DISPOSAL



- Coopers of Stortford use recyclable or recycled packaging where possible.
- Please dispose of all packaging, paper, cartons, packaging in accordance with your local recycling regulations.
- Coopers of Stortford use recyclable or recycled packaging where possible.
- Please dispose of all packaging, paper, cartons, packaging in accordance with your local recycling regulations.
- Recyclable material details: wooden frame, steel mechanism, motor, 100% polyester fabric.

- Plastics, polybags – Contains the following recyclable plastic.

Code & Symbol	 LDPE (bag)	 PS (foam)	 OTHER (polyester fabric, wood)
Type of Plastic	Low Density Polyethylene	Polystyrene	Please Specify (includes ABS, Nylon)
Commonly used for	Shopping bags, bread bags, squeeze bottles, stretch/pallet wrap, bubble wrap, multi-pack can holders	Insulation boxes, water cups, protective packaging inserts, take away containers	CD's, crisp packets, various flexible packaging, baby bottles, sunglass lenses
Notes	Usually recyclable supermarket deposit points. Check other plastic films as any non-polythene film e.g. cling film, crisp packets film lids	Not commonly recycled but waste management centres will recycle it.	Not often or widely recycled

- At the end of the product's lifespan please check with your local council authorised household waste recycling centre for disposal.

