

Wheeled Organiser Drawers H141

Instructions for Use

Please read and retain these instructions for future reference

v001: 29/07/20



Dimensions

33cm *38cm *63cm (LWH)

Composition

Iron/PP

Max weight load:

17kgs (each drawer 2kg, top 5kg)

- Rolling organiser trolley
- Great for organisation and to keep your home tidy
- 6 pull out drawers and top shelf
- 4 lockable rolling casters
- Sturdy metal frame

ASSEMBLY INSTRUCTIONS / INSTRUCTIONS FOR USE:

Unpack the components carefully. Please check all parts have been removed from the packaging.

No.	Part	Pcs
A		2
B		1
C		4
D		6
E		6
F		8
G		1
H		6
I		4
J		4

*Calls cost 7 pence per minute plus your telephone company's network access charge

Head Office, 11 Bridge Street,
Bishop's Stortford CM23 2JU
Tel: 0844 482 4400*
Fax: 01279 756 595
www.coopersofstortford.co.uk

Coopers
OF STORTFORD

Wheeled Organiser Drawers H141

Instructions for Use

Please read and retain these instructions for future reference

v001: 29/07/20

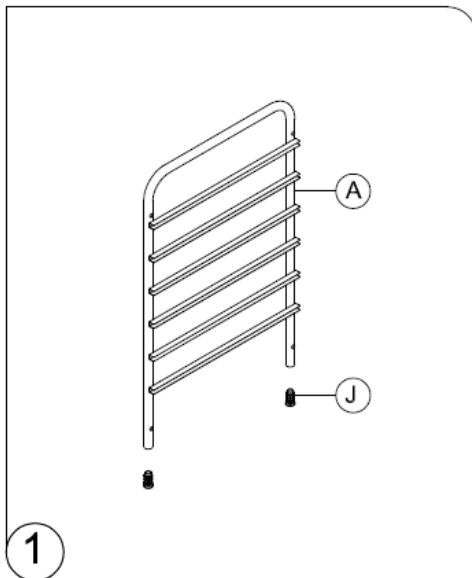

1

Insert part J into the feet of part A 4x.

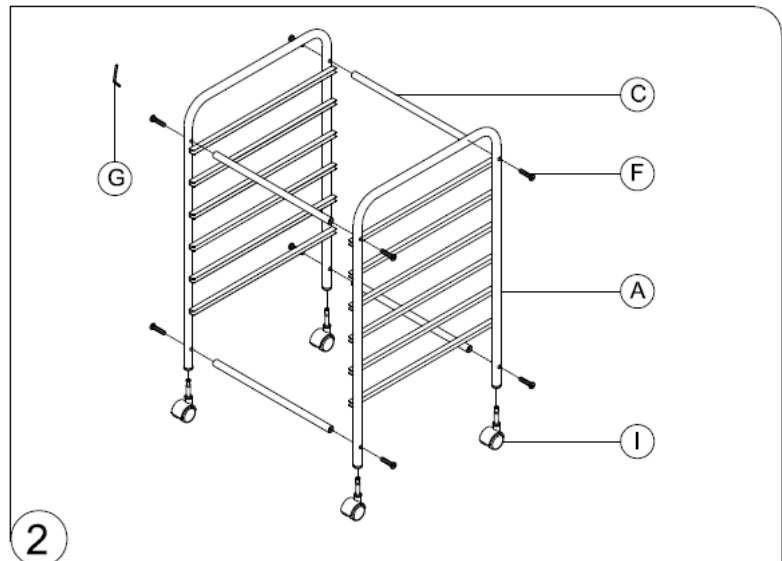

2

Attach part I to parts J. Attach horizontal bars C (x4) to part A using bolts F using an Allen key (G)

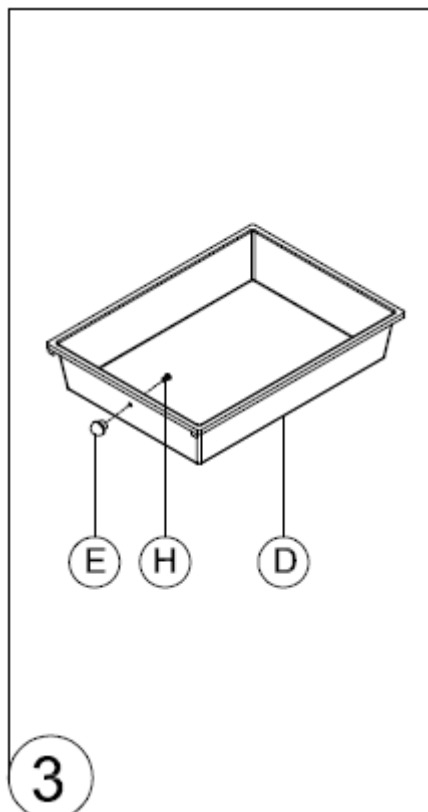

3

Attach part 3 using bolt H to drawer D. (6x)

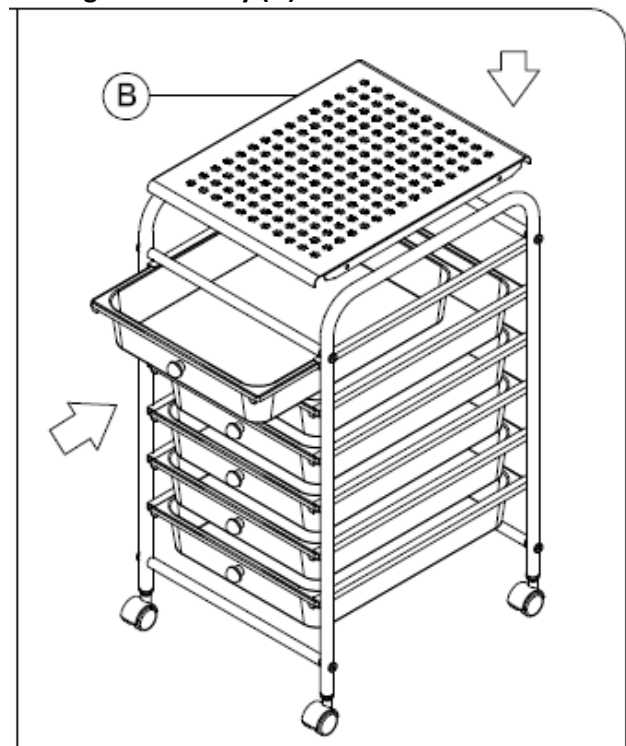

Slide drawers in and hook part B over the top of the assembly.

*Calls cost 7 pence per minute plus your telephone company's network access charge

Head Office, 11 Bridge Street,
Bishop's Stortford CM23 2JU
Tel: 0844 482 4400*
Fax: 01279 756 595
www.coopersofstortford.co.uk

Coopers
OF STORTFORD

CARE AND CLEANING INSTRUCTIONS

- Wipe clean with a dry cloth.

DISPOSAL

- Coopers of Stortford use recyclable or recycled packaging where possible.
- Please dispose of all packaging, paper, cartons, packaging in accordance with your local recycling regulations.
- Plastics, polybags – Contains the following recyclable plastic.



Code & Symbol	
Type of Plastic	Polypropylene
Commonly used for	Microwaveable food containers, yoghurt pots, butter tubs, disposable plates and cups
Notes	Commonly recycled and collected from household recycling bins (packaging tape itself not recyclable but does not interfere with cardboard)

- At the end of the product's lifespan please check with your local council authorised household waste recycling centre for disposal.