

Set 4 Bronze Lawn Edging with Solar Lights

K244 v02: 17/01/22

Please read and retain these instructions for future reference

GAINSBOROUGH
Garden & Wildlife



Always position in direct sunlight

Dimensions

(H) 34 x (W) 49 x (D) 2.2cm

- POLYSILICON SOLAR PANEL 2V 70MAH
- SOLAR PANEL STAKE – 1M AWAY
- 2 IN 1 CREATE A BORDER AND LIGHT UP THE WALK WAY
- 113CM WIRE BETWEEN EACH SECTION OF BORDER

1 x 1.2V Ni-MH AA 400mah Rechargeable

ASSEMBLY INSTRUCTIONS / INSTRUCTIONS FOR USE:

Unpack the components carefully. Please check all parts have been removed from the packaging.

Before using first time

Allow lights to charge for at least 8 hours in full sunlight with the ON/OFF switch in the ON position. The ON/OFF switch is located under the solar panel. Once the batteries are fully charged, set the ON/OFF switch to ON. If the lamp does not turn on after dark refer to Maintenance section.

Find an ideal Place for the Solar Light.

Place the solar light in an area where it will receive direct sunlight for at least 8 hours per day. The number of hours the light will illuminate is directly proportional to the hours of sunlight it receives. If the light is placed in a shaded area, it will not be able to fully charge and its illumination time will be limited. Do not place the light near other outdoor lighting like porch or streetlights. These may fool the sensor and keep the light from coming on, or cause it to turn off automatically

Parts

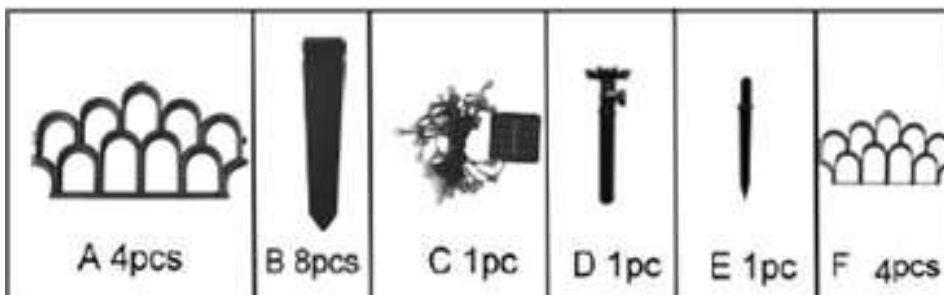

BEFORE FIRST USE: Remove the protective film from the solar panel.

CHARGING AND OPERATION:

1. Set button (located underneath solar panel) to "ON" position. Charge the solar product by placing it under direct sunlight for at least 8 hours.
2. The light will work automatically. It will automatically charge under direct sunlight during the daytime and illuminate at night.

Set 4 Bronze Lawn Edging with Solar Lights K244 Instructions for Use

Please read and retain these instructions for future reference

v002:17/01/22

3. Set "ON/OFF" button to "ON" position for steady on light, press the "MODE" button to activate flash light function. If you like to go back to steady on light, then press "MODE" button again to deactivate flash light.

NOTE: In order to verify that the button is correctly in the "ON" position, cover the solar panel with your hand and the light should turn "ON" automatically.

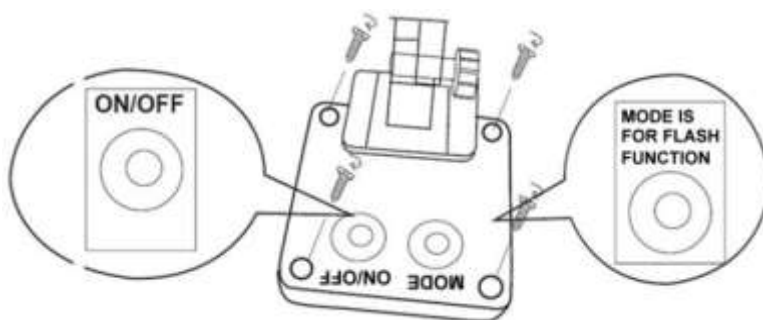

TROUBLESHOOTING

Make sure the button is set to "ON" position and keep the solar panel clean. If solar product does not light up after it has been used for around 8 – 12 months, replace the rechargeable batteries as they may be weak or worn out. (Battery 1pc "AA" 1.2V 300mAh, Ni-MH, Rechargeable– Same equivalent type as recommended must be used).

BATTERY REPLACEMENT

Step1: Unscrew the battery compartment cover by using a Phillips head screwdriver (not included).

Step2: Remove the exhausted battery and install 1pc new AA rechargeable battery according to the +/- symbol polarity indicated on the battery compartment. Open the compartment carefully and ensure that welding wires inside the battery terminals are not damaged.

Step3: Replace battery compartment cover, screw it back into position and ensure is properly sealed.

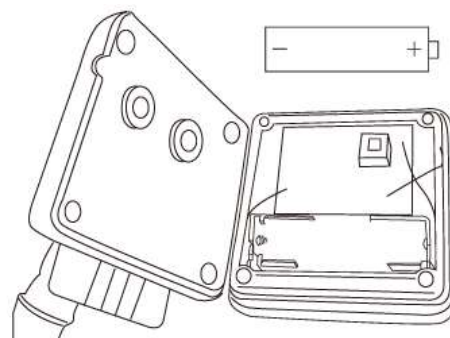

ASSEMBLY INSTRUCTIONS

To easily insert stakes into the ground, it is recommended to wet the ground first. To avoid damaging garden stakes when inserting into the ground, select a spot in soft, rock-free soil. Insert the base of the stake first then gently insert the rest of the stake into the base. DO NOT push directly against the solar cell or the ornament housing containing the actual LED light.

*Calls cost 7 pence per minute plus your telephone company's network access charge

The Enterprise Department
Head Office: 11 Bridge Street
Bishop's Stortford, CM23 2JU
Tel: 0844 482 4400*
Fax: 01279 756 595
www.coopersofstortford.co.uk

Set 4 Bronze Lawn Edging with Solar Lights K244 Instructions for Use

Please read and retain these instructions for future reference

v002:17/01/22

1. The bulbs and stakes need to be assembled first. Push the bulb into place then move onto the next bulb. Affix total of 9 lights one after the other. Press each one down until it locks (see image). When all bulbs are in place (36), fit the backing section and clip into place, press down to lock them. Make sure it is clipped in place then turn the panel over and push the bulb in to place. Then move on to the next panel.
2. Slide the stakes into the holes
3. Connect the panels.



Panel open with lights clipped in place.



Panel with back cover fitted.

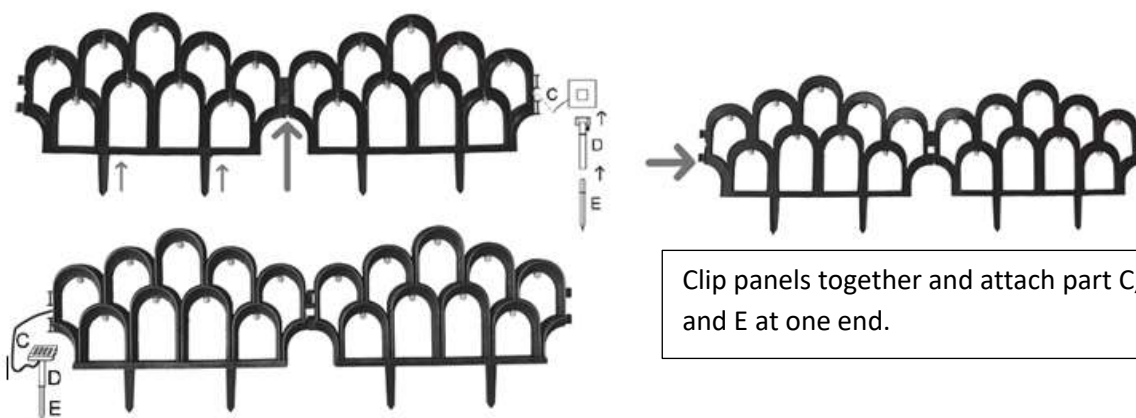

Clip panels together and attach part C, D and E at one end.

Care and Maintenance Recommendations

1. Clean solar panel with a soft sponge every couple of weeks.
2. Make sure all connectors are still tight and no water getting in.
3. During the winter if you can bring it inside and give a good clean ready for next year.

DISPOSAL

- Coopers of Stortford use recyclable or recycled packaging where possible.



*Calls cost 7 pence per minute plus your telephone company's network access charge

The Enterprise Department
Head Office: 11 Bridge Street
Bishop's Stortford, CM23 2JU
Tel: 0844 482 4400*
Fax: 01279 756 595
www.coopersofstortford.co.uk

Set 4 Bronze Lawn Edging with Solar Lights K244 Instructions for Use

Please read and retain these instructions for future reference

v002:17/01/22

- Please dispose of all packaging, paper, cartons, packaging in accordance with your local recycling regulations.
- Plastics, polybags – this is made from the following recyclable plastic.

Code & Symbol	
Type of Plastic	Polypropylene
Commonly used for	Microwaveable food containers, yoghurt pots, butter tubs, disposable plates and cups
Notes	Commonly recycled and collected from household recycling bins (packaging tape itself not recyclable but does not interfere with cardboard)

- At the end of the product's lifespan please check with your local council authorised household waste recycling centre for disposal.



*Calls cost 7 pence per minute plus your telephone company's network access charge

The Enterprise Department
Head Office: 11 Bridge Street
Bishop's Stortford, CM23 2JU
Tel: 0844 482 4400*
Fax: 01279 756 595
www.coopersofstortford.co.uk