

Rattan Garden Furniture Set – 4pc

K354 v001: 25/10/21

Please read and retain these instructions for future reference

GAINSBOROUGH
Garden & Wildlife



- 2-person assembly recommended
- **WEIGHT LIMIT FOR SINGLE SOFA 100KG**
- **WEIGHT LIMIT FOR DOUBLE SOFA 200KG**
- **WEIGHT LIMIT FOR TABLE: 25KG**

Dimensions

Single Sofa – H82 x W58 x D62cm

Double Sofa – H82 x W108 x D62cm

Table – H38.5 x L71 x W41cm

- **5CM THICK GREY SHOWER PROOF CUSHIONS**
- **5MM TEMPERED CLEAR GLASS**
- **MADE OUT OF POLYRATTAN**
- **IN A 2 TONE POLY RATTAN**
- **SEATING CAPACITY 4**
- **REMOVABLE CUSHION COVERS THAT CAN BE WASHED (HAND WASH ONLY)**
- **INNER FRAME MADE FROM STEEL**

NOTES TO CUSTOMERS:

- Please check that your parcel contains all the parts listed in the parts lists.
- For the protection of the furniture, we recommend that the product is placed on a protected surface during assembly to prevent any damage.
- Please ensure that you read the instructions before assembling the product.
- Please do not force or over tighten the nuts. If a nut becomes stuck, unscrew it and start again.
- Ensure you have plenty of space to assemble the item in, it is also recommended that you assemble the item close to where it will be kept.





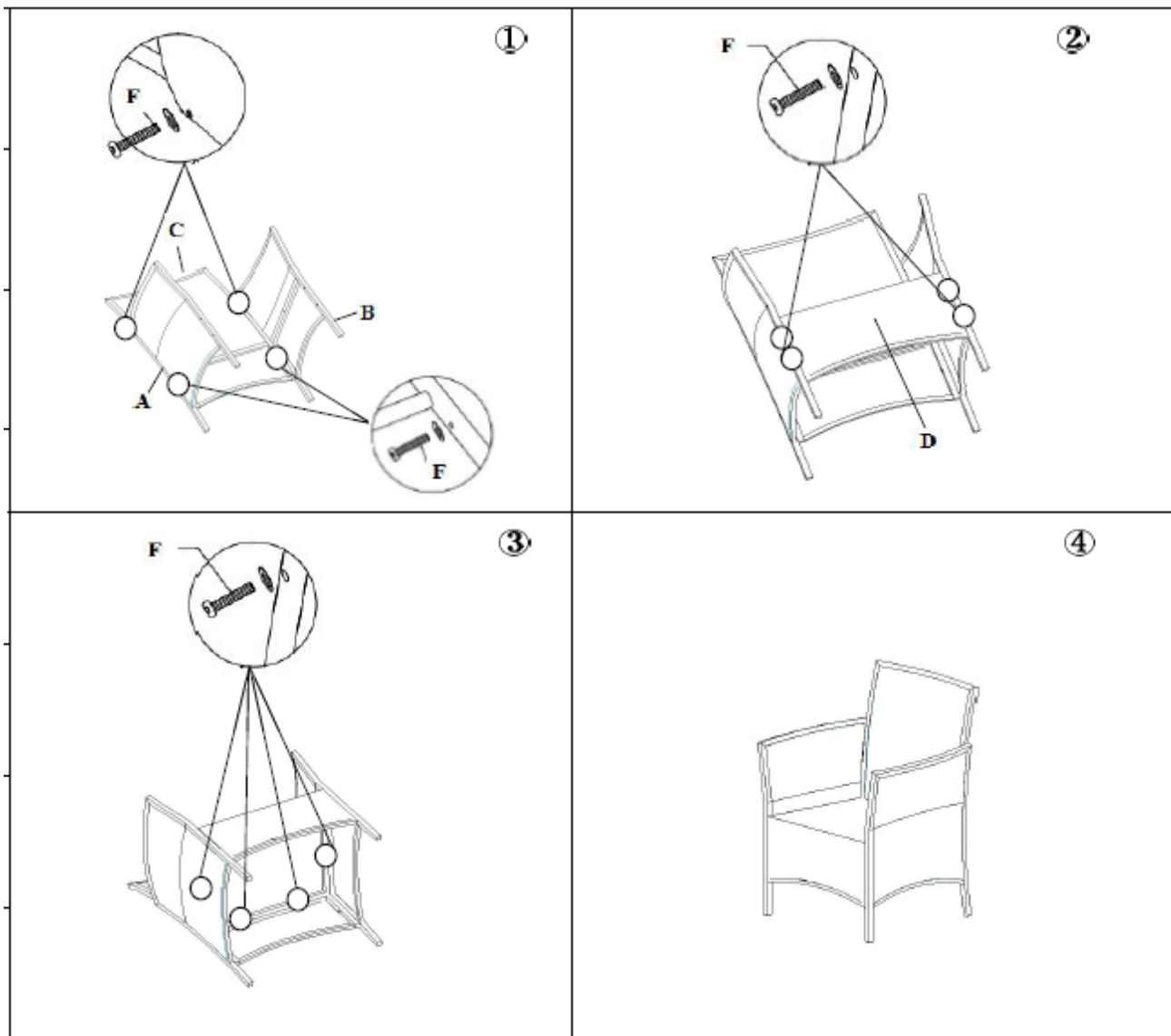

Parts – Single Sofa

A		1PC	D		1PC
B		1PC	F		12 PCS
C		1PC	G		1PC

Single Sofa Assembly

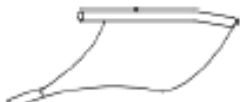

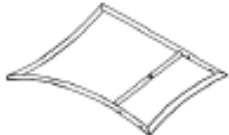
Parts – Double Sofa

A		IPC	D		IPC
B		IPC	F	 M6*35 MM	14 PCS
C		IPC	G		IPC

Double Sofa Assembly

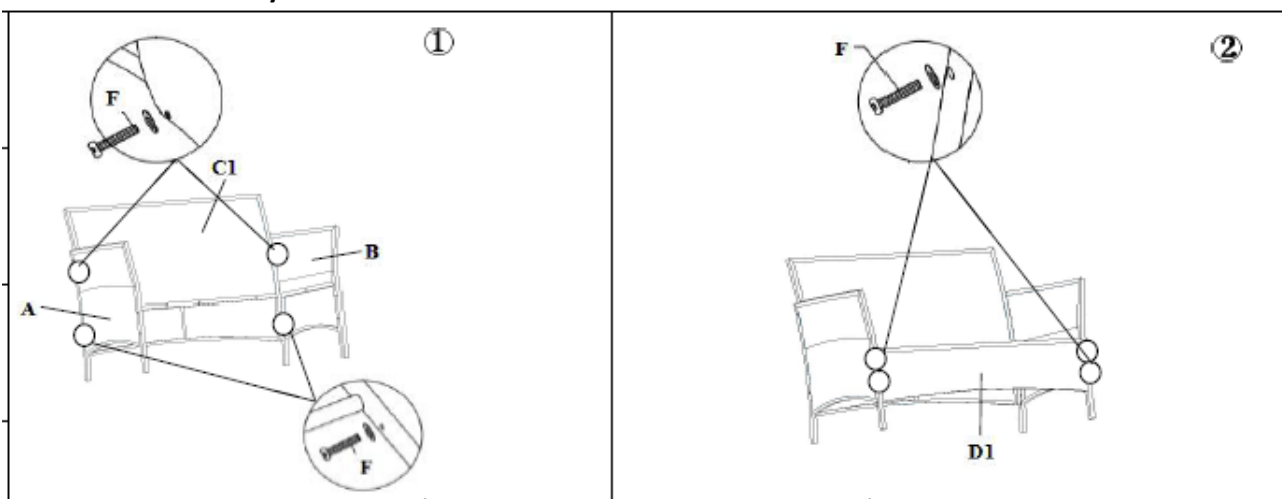

Rattan Garden Furniture Set – 4pc K354



Please read and retain these instructions for future reference

Instructions for Use

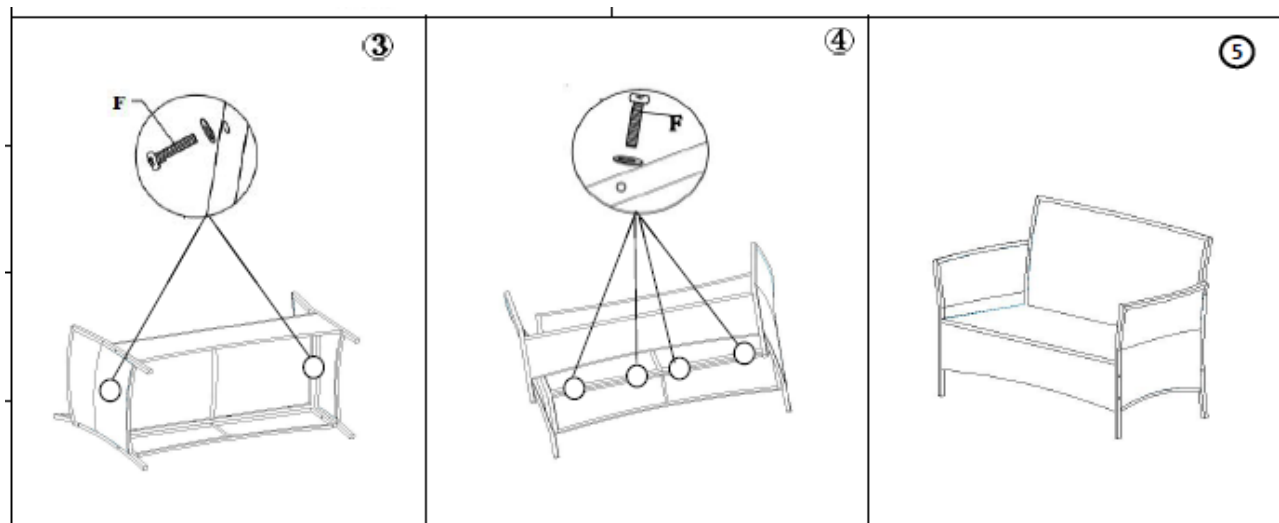
v001: 25/10/21

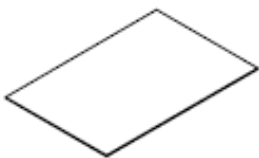
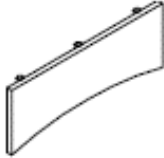
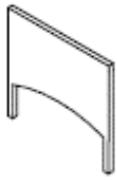

Parts – Table

H		1 P C	J		2PCS
I		2PCS	E	 M6*30 MM	8PCS

*Calls cost 7 pence per minute plus your telephone company's network access charge

The Enterprise Department
 Head Office: 11 Bridge Street
 Bishop's Stortford, CM23 2JU
 Tel: 0844 482 4400*
 Fax: 01279 756 595
www.coopersofstortford.co.uk

Table Assembly

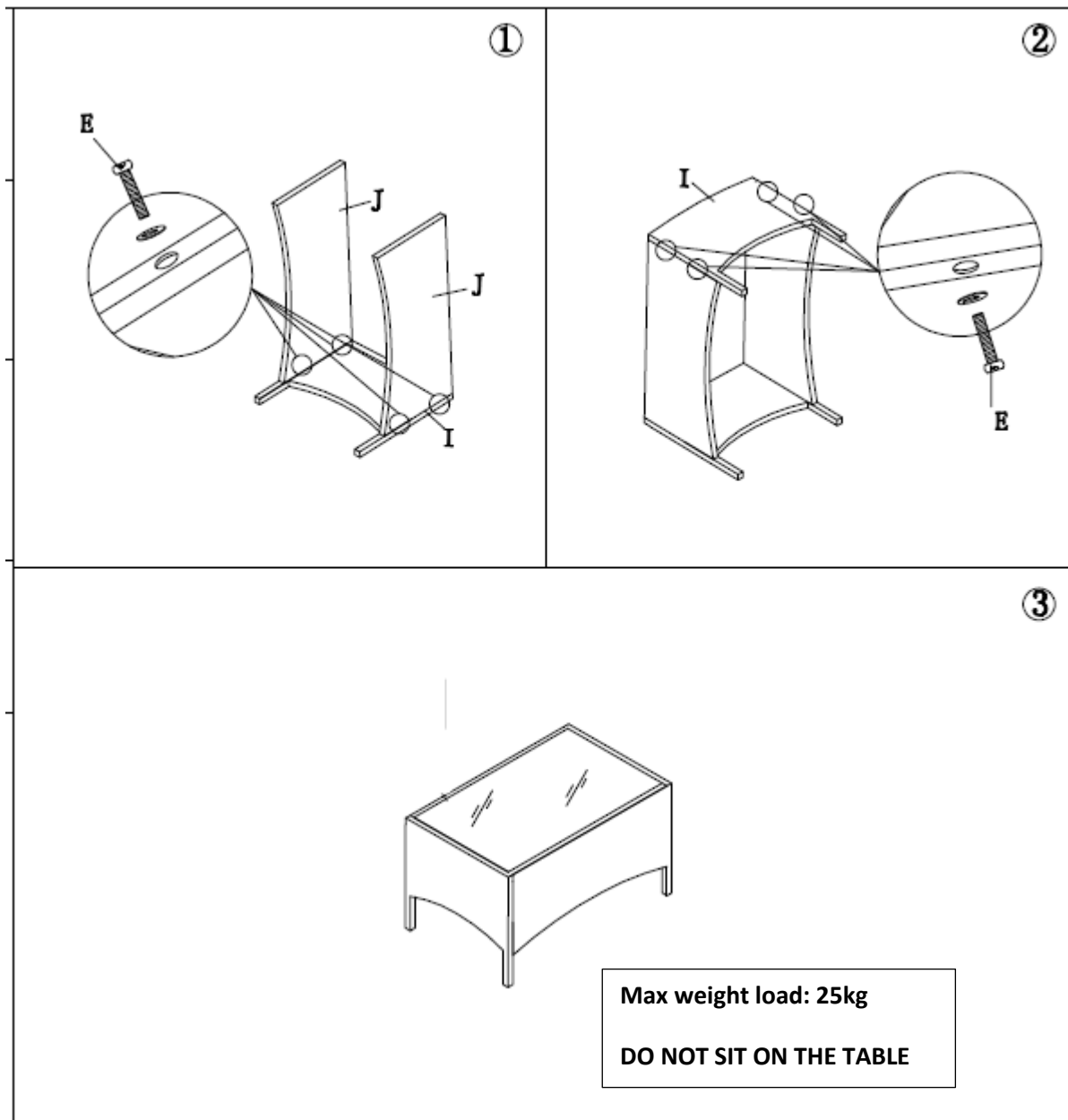

IMPORTANT

After Assembly, once you have tightened the nuts go round just double checking they are tight.

Before each use, regularly check the nuts, bolts and fixings are tight.

The seat must be placed on an even surface.

Do not place the legs in between gaps in paving slabs or on pebbled or uneven surface.

MAINTAINANCE & CLEANING INSTRUCTIONS:

- Check all fixings are secure, and all parts are firmly in place before each use.
- Tighten where necessary.
- Protect from adverse weather.
- Gently wipe clean with a damp cloth.
- Store in a dry place.
- Do not store when wet.

DISPOSAL

- Coopers of Stortford use recyclable or recycled packaging where possible.
- Please dispose of all packaging, paper, cartons, packaging in accordance with your local recycling regulations.
- Plastics, polybags – this is made from the following recyclable plastic.



Code & Symbol	 HDPE
Type of Plastic	High-Density Polyethylene
Commonly used for	Milk bottles, cleaning product bottles, yoghurt pots, butter tubs and other food containers
Notes	Commonly recycled and collected from household recycling bins. Check with your local authority

- At the end of the product's lifespan please check with your local council authorised household waste recycling centre for disposal.