

# Wind Up Solar Radio

Item No: P945

## Instructions for Use

v001: 19/08/25

Please read and retain these instructions for future reference

# BERGSTRÖM



**Power Details:** Battery Type & details: 1\*Lithium Battery 600mAh included  
Voltage details: 2.7- 4.2V

**Accessories:** 1x USB cable

### Function:

- LED flashlight
- FM/AM
- Emergency mobile phone charging
- Charge/discharge protection
- Multi-functional charging methods:
- Hand crank charging /Solar charging /USB charging
- IPX3 waterproof

### Manual:

- Turn the power button clockwise and adjust the volume.
- Choose AM, FM station and pull the radio's antenna up to receive a better signal.
- Turn the tuning knob to select a channel. The signal indicator will turn green when the radio receives a signal.

### Flashlight use:

- Press the flashlight switch to turn it ON.
- Flashlight switch to turn it OFF.

### Solar power/Hand crank/USB charging

#### A. A solar charging

- The radio can be fully charged after 66 hours by placing it in the direct sunlight. When the red light is on, the radio is charging.

#### B. Hand crank charging

- Pick up the crank.
- When using the radio for the first time, or if the radio has not been used for more than 60 days, hand crank clockwise or counterclockwise for 3 to 5 minutes continuously to activate the built-in battery. The red indicator will light up when the radio is charging.
- If charging the radio by hand continuously, shake the hand joystick continuously for 1 minute (hand crank frequency  $\geq 130$  times), you can use the flashlight for 15-20 minutes; radio playback (at medium volume) for 15-20 minutes; phone charging calls for 3-5 minutes time.

#### C USB charging

- Use the Type-C interface to connect to the radio and then the other end of the USB interface to connect to a computer. The red light is on when the radio is charging.

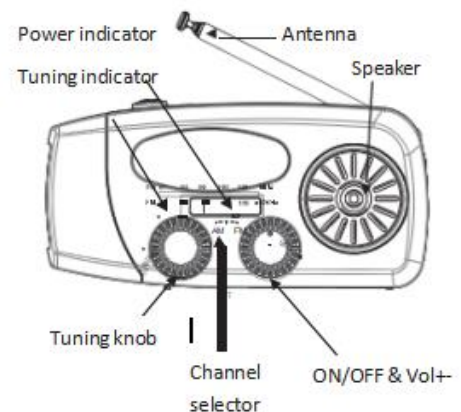

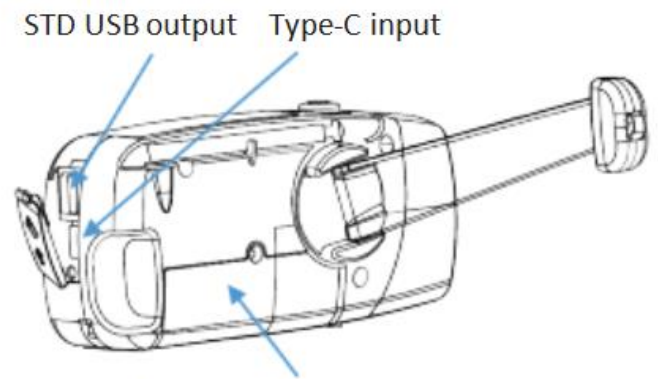
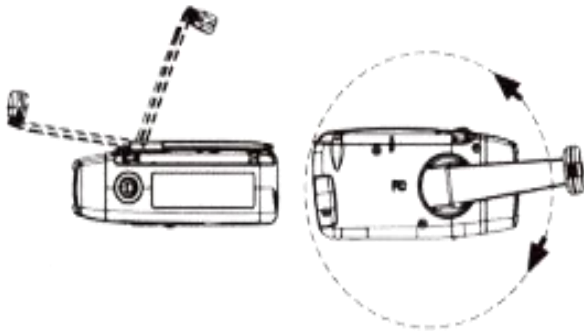
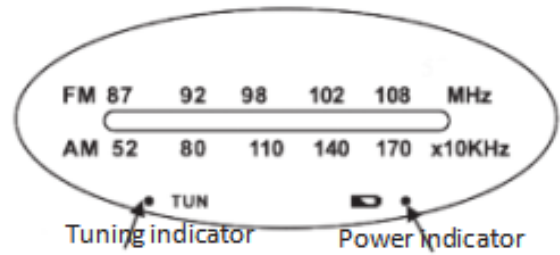
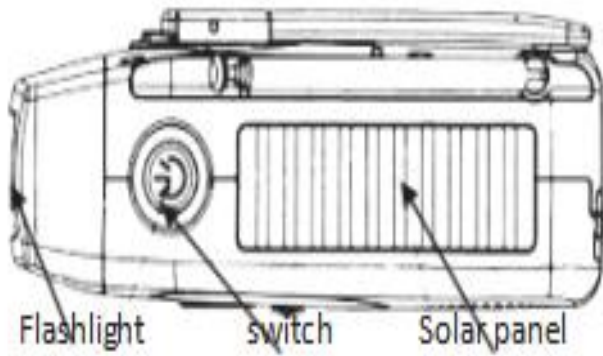

### Phone charging

- Open the rubber cover.
- Use a USB cable to connect the phone, the phone will automatically charge if there has residual charge in the item. No need to crank the radio.

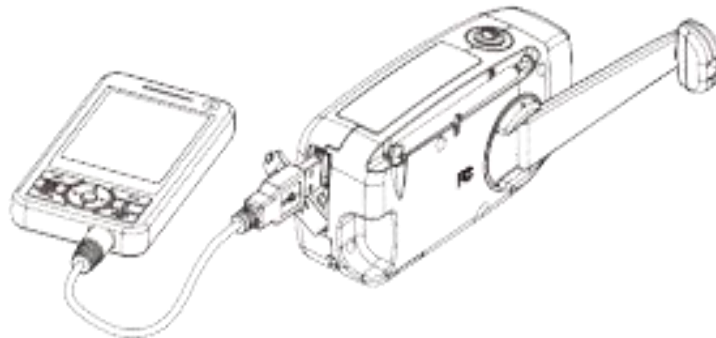

### Charging protection

- When the red charging indicator light flashes, it means the radio is charging. After fully charged, the red indicator light is always on.

### Discharge protection

- When the battery is overloaded or short-circuited, the output will stop automatically.
- When the voltage is lower than 2.5V, the power supply will cut off automatically.

### Specification:

- Dimension: 128 x 60 x 45 (mm)
  - Weight: 210g
  - Maximum power: 1.5W
  - Frequency:
- AM: 520~1710 KHZ  
 FM: 87~108 MHz
- Working voltage: 2.7~4.2V
  - Battery: 3.7V/600mAh

## Maintenance:

- Wipe the casing of the radio with a soft cloth.
- Use qualified products to clean the flashlight lens.
- Do not use any rough tools or solvents to clean the radio.
- The radio is not completely waterproof, just IPX3 level. Therefore, it is forbidden to place it in water for a long time.
- When the radio has been idle for more than 60 days, or when it is used for the first time please use hand-crank charging or solar charging for 3-5 minutes to activate the built-in battery.

## ALWAYS POSITION THE SOLAR PANEL IN DIRECT SUNLIGHT

## WARNINGS AND SAFETY INSTRUCTIONS:

WHEN USING ANY APPLIANCE, BASIC SAFETY PRECAUTIONS SHOULD ALWAYS BE FOLLOWED:

- READ ALL INSTRUCTIONS BEFORE USE.
- FOR DOMESTIC OUTDOOR USE ONLY.
- BEFORE USE, CHECK THOROUGHLY FOR ANY DEFECTS AND DO NOT USE IF DEFECTS ARE FOUND. TAKE CARE NOT TO DROP THE APPLIANCE AS HEAVY IMPACTS MAY CAUSE INTERNAL DAMAGE.
- THE USE OF ANY ACCESSORY OR ATTACHMENTS NOT RECOMMENDED BY COOPERS OF STORTFORD MAY CAUSE INJURIES AND INVALIDATE ANY WARRANTY YOU MAY HAVE.
- REPLACE THE BATTERIES IF LEFT FOR LONG PERIODS OR NO LONGER CHARGING.



CHECK CORRECT POLARITY



DO NOT MIX NEW  
AND USED BATTERIES



DO NOT DISPOSE  
IN FIRE



SEEK MEDICAL ASSISTANCE  
IF SWALLOWED

- DO NOT SHORT CIRCUIT THE BATTERY TERMINALS.
- ENSURE THE BATTERY COMPARTMENT IS RE-SECURED BY THE SCREW OR SECURING DEVICE.
- BATTERY DISPOSAL: SPENT OR EXPIRED BATTERIES MUST BE DISPOSED OF AND RECYCLED IN COMPLIANCE WITH YOUR LOCAL AUTHORITY REGULATIONS.
- **KEEP BATTERIES AWAY FROM CHILDREN AND PETS.**

## CARE AND CLEANING INSTRUCTIONS

- REGULARLY CHECK AND WIPE CLEAN THE SOLAR PANEL AND REMOVE ANY OBSTRUCTIONS.
- DO NOT USE ABRASIVE CLEANERS OR SHARP UTENSILS TO CLEAN THIS APPLIANCE.
- WIPE SURFACES WITH A SOFT DRY CLOTH. DRY THOROUGHLY BEFORE FURTHER USE.
- DO NOT IMMERSE IN WATER.
- STORE THE APPLIANCE IN A COOL, DRY PLACE.

## DISPOSAL

- Coopers of Stortford use recyclable or recycled packaging where possible.
- Please dispose of all packaging, paper, cartons in accordance with your local authority recycling regulations.
- At the end of the product's lifespan please check with your local council authorised household waste recycling centre for disposal.

**Distributed by / Verteilt durch / Distribué par/ Distribútor / Distribuuje.**

The Enterprise Department Ltd, Trading as Coopers of Stortford.

**UK address:** 11 Bridge Street, Bishops Stortford

Herts, UK, CM23 2JU

 0330 331 0300

 [enquiries@coopersofstortford.co.uk](mailto:enquiries@coopersofstortford.co.uk)

 <https://www.coopersofstortford.co.uk>

**The Enterprise Department Ltd, Trading as – Coopers of Stortford**

D.S.B. LD, 160 Bd. De Fourmies, 59100 Roubaix, France

 0330 331 0300

 [enquiries@coopersofstortford.co.uk](mailto:enquiries@coopersofstortford.co.uk)

 <https://www.coopersofstortford.co.uk>

DE/FR/CZ/SK : **3Pagen**

Hergestellt für 3Pagen

Sankt-Joeris-Strasse 16-28

52477 Alsdorf

 +49 (0) 2404/980-204

 [kontakt@3pagen.de](mailto:kontakt@3pagen.de)

 [www.3pagen.de](http://www.3pagen.de)

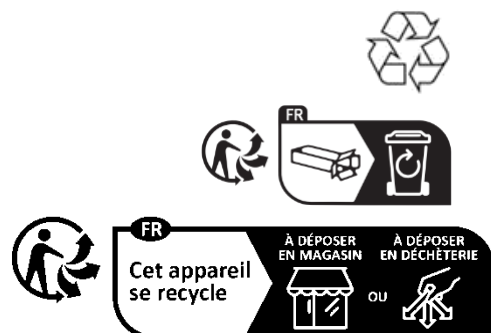

**UK  
CA**

**CE**

