

LOG SPLITTER Instructions

7172

Please keep this manual in a safe place for future reference.

To prevent the risk of serious injury, please read this manual fully before use.

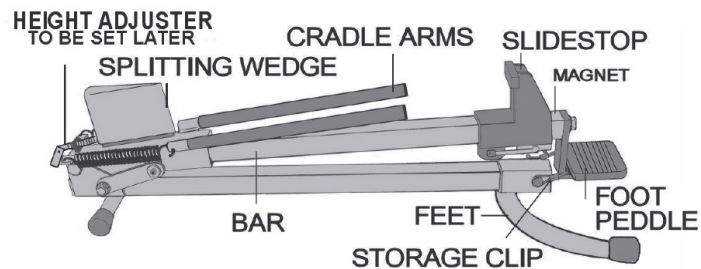

ASSEMBLY & USAGE

- Ensure that the log splitter is sited on flat, level ground and there is adequate grip underfoot.
- Apply downward pressure to remove storage clip and allow pressure to release slowly (see right)
- Attach feet, close the log splitter and re-fit the storage clip. (see below)

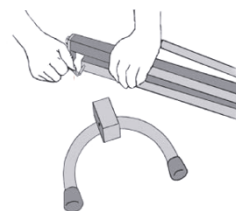
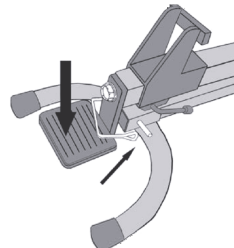
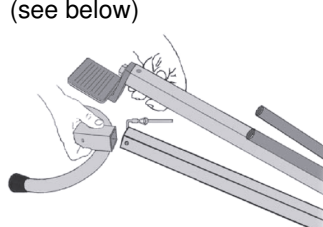

- Turn the height adjuster (at opposite end to the foot pedal) 2-3 revolutions anti-clockwise. (see right)
- Unclip the storage clip, allow the pressure bar to rise and replace the clip when the bar is raised. (see below)

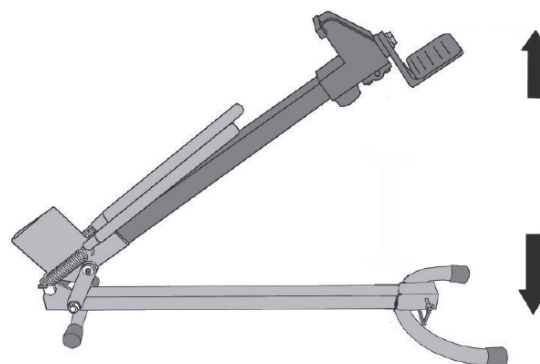
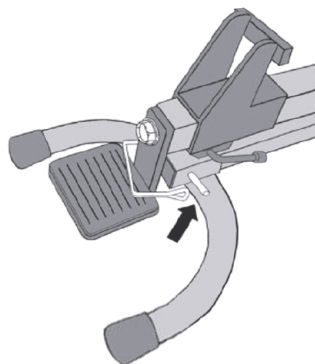
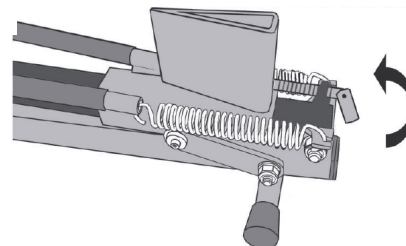

- Insert log and slide the rear support up to the back of the log. The magnet will hold this in place.
- Place a foot onto the foot plate and press down firmly in a controlled manner. This will split the log and the pieces will drop to the ground.

Note - It may take more than one attempt to split a log successfully.

- After use, clean and then depress foot plate and re-attach clip to secure in folded down position.
- To maintain, occasionally sharpen the splitting wedge using a file or sharpening stone and ensure any moving parts are lubricated with anti-rust machine oil.

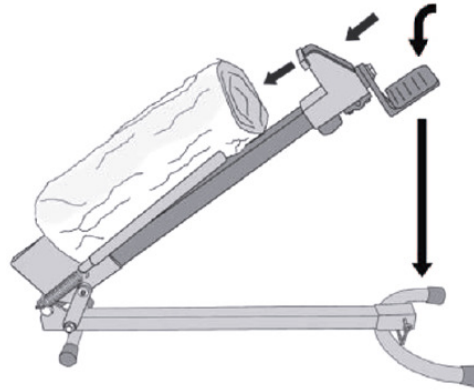

WARNING

- Always use appropriate protective equipment when using this product. Heavy duty gloves, goggles and suitable, strong footwear should be worn at all times.
- Be sure to use with care. Avoid over-stretching and over-balancing.
- Maintain a safe distance from the unit when unclipping.
- Do NOT lean over log splitter whilst in use.
- Keep work area clear and well lit.
- Before use, always check the log splitter is in good working order, including checking all nuts and bolts are secure. Do NOT use if damaged.
- Stand clear of the log splitter when in use. Ensure that the area around the log splitter is also kept clear of people to avoid injury caused by splinters as the wood splits.
- Do NOT use on uneven or slippery surfaces.
- Keep away from children. Do NOT let children near to the log splitter when in use.
- When not in use, store in a cool, dry place.
- Wood that has been allowed to dry for up to 2 years will be easier to split than damp or freshly cut wood. If wood fails to split, allow to dry out fully before attempting again.
- Do NOT attempt to catch pieces of wood as they split, allow them to drop to the ground before collecting.
- Do NOT exceed the maximum cutting dimensions below. If need be, cut down to a smaller size before attempting to split again.
- Foot pedal adjusts up to 30-33cm in height
- **Cutting Length: 45.7cm (18in)** **Cutting Diameter: 25.4cm (10in)**

PACKAGING

- Dispose of the packaging at your local recycling centre.
- Dispose of paper and carton separately from plastic bags at your local recycling centre.
- Dispose of the item at the end of its lifespan at your local authorised household waste recycling centre.

Head Office:
11 Bridge Street
Bishops Stortford
Hertfordshire
CM23 2JU

Customer Services:
Tel: 0844 482 4400
Fax: 01279 756595

Coopers
 OF STORTFORD