

Weight limit: 20kgs

Parts

No.	Pic.	Descript.	Quantity
1		Castors without brakes <i>(packed in the small drawer)</i>	4 pcs
2		Tapping Screws <i>(packed in the small drawer)</i>	16 pcs

- Tools Required: 1 x cross head screwdriver (not included)
- 2 Person Assembly
- Please ensure that all parts are present prior to assembly.
- Please ensure that all parts are checked regularly and tightened where required.

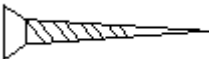
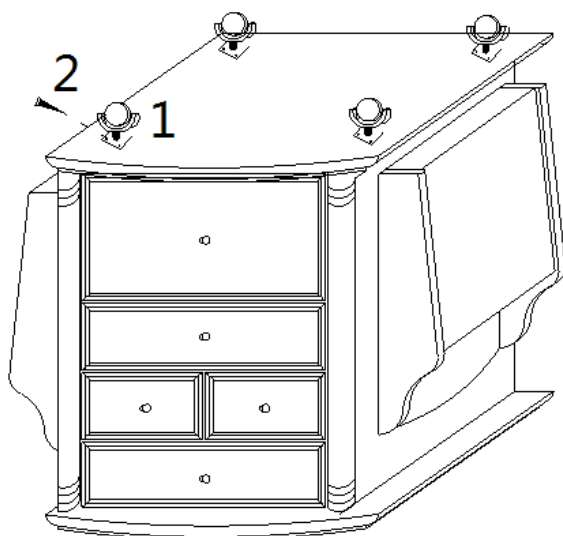

Step 1

Turn unit upside down and fit castors in the pre-drilled holes using 4 tapping screws for each castor.

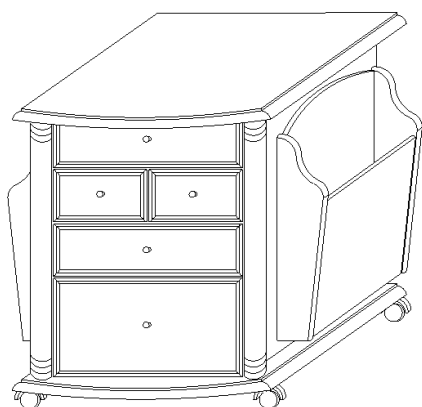

Step 2

Turn unit right side up.

DISPOSAL



- Coopers of Stortford use recyclable or recycled packaging where possible.
- Please dispose of all packaging, paper, cartons, packaging in accordance with your local recycling regulations.
- Plastics, polybags – Contains the following recyclable plastic.

Code & Symbol	 PS
Type of Plastic	Polystyrene
Commonly used for	Insulation boxes, water cups, protective packaging inserts, take away containers
Notes	Not commonly recycled but waste management centres will recycle it.

- At the end of the product's lifespan please check with your local council authorised household waste recycling centre for disposal.

Head Office, 11 Bridge Street,
Bishop's Stortford CM23 2JU
Tel: 0844 482 4400*
Fax: 01279 756 595
www.coopersofstortford.co.uk

Coopers
OF STORTFORD

*Calls cost 7 pence per minute plus your telephone company's network access charge