

Please read instructions and save for future reference

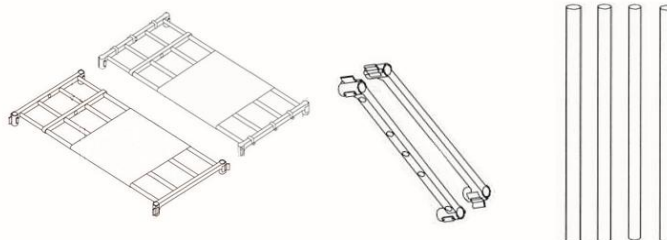

Parts

2 x pre – assembled shelves

2 x plastic brackets

4 x stainless steel poles

Assembly:

1, Insert the 4 stainless steel poles into the round clips of the 2 plastic brackets. Secure into place using the hinged side of the clip. Lock all four sides before continuing.

2, Slide the first pre-assembled shelf over the four corners of the steel poles. Secure into place using the hinged side of the clip. Lock all four sides before continuing to the last step. Repeat the above steps with the top shelf.

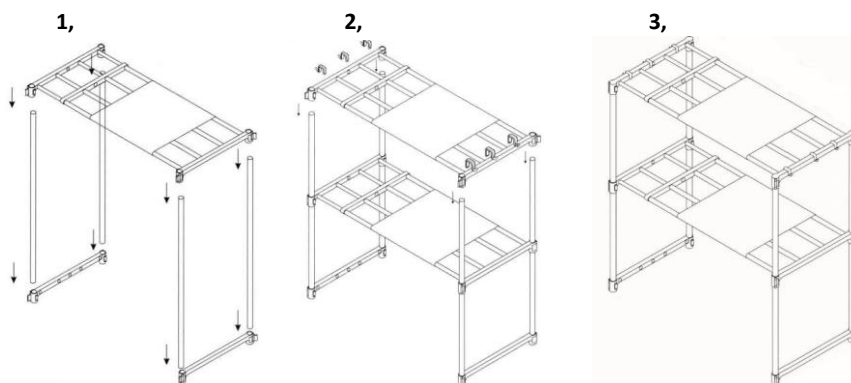

NOTE:

Do not use for storage of flammable, hazardous or fragile goods. Do not allow children to climb or grab the unit. Maximum weight load is **1.5KG**. Assembled dimensions (fully extended): L85 cm x W30.5 cm H60 cm

Care:

Clean with a mild detergent, dry before positioning goods back onto shelf.

Packaging:

Dispose of packaging at your local recycling centre. Dispose of paper and carton separately from plastic bags at your local recycling centre. Dispose of item at the end of its lifespan at your local authorised household waste recycling centre.



