

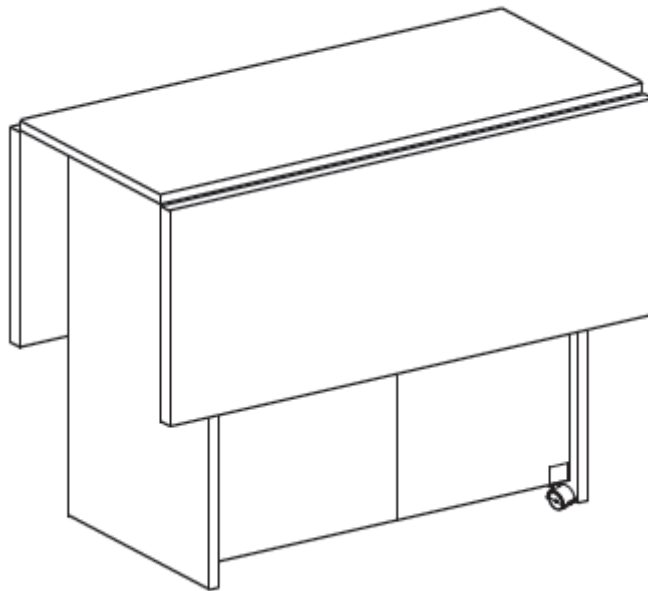











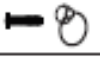





Please read and retain these instructions for future use:

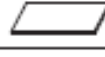

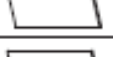
List of parts:

No	Hardware List	Qty
1	Screw 	50pcs
2	Wood Dowel 	20pcs
3	Camlock Screw/Nut 	20pcs
4	Hinge 	6pcs
5	Pull Knob 	2pcs
6	Door Hinge 	4pcs
7	Stopper 	8/2pcs
8	Caster 	2pcs
9	Protective Pad 	4pcs
10	Pin Support 	4pcs

No	Parts List	Qty
A	799X298 	1pcs
B	799X449 	2pcs
C	720X298 	1pcs
D	720X298 	1pcs
E	658X236 	1pcs
F	670X297 	2pcs
G	668X278 	2pcs
H	582X236 	1pcs
I	283X230 	1pcs

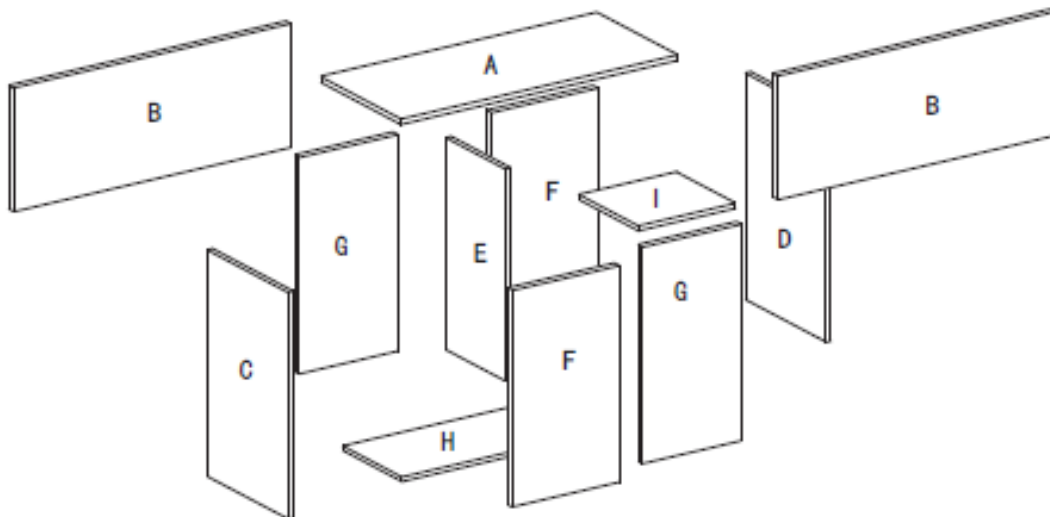

USEFUL TIPS BEFORE YOU START THE ASSEMBLY:

- Read each step carefully before starting.
- It is important that each step is performed in the correct order.
- Identify, sort and count the parts before assembly.
- Assemble the item on cardboard to prevent scratching or damage.
- Clean the product with a mild cleaner using a soft dampened cloth. Do not use harsh or abrasive cleaners or pads.

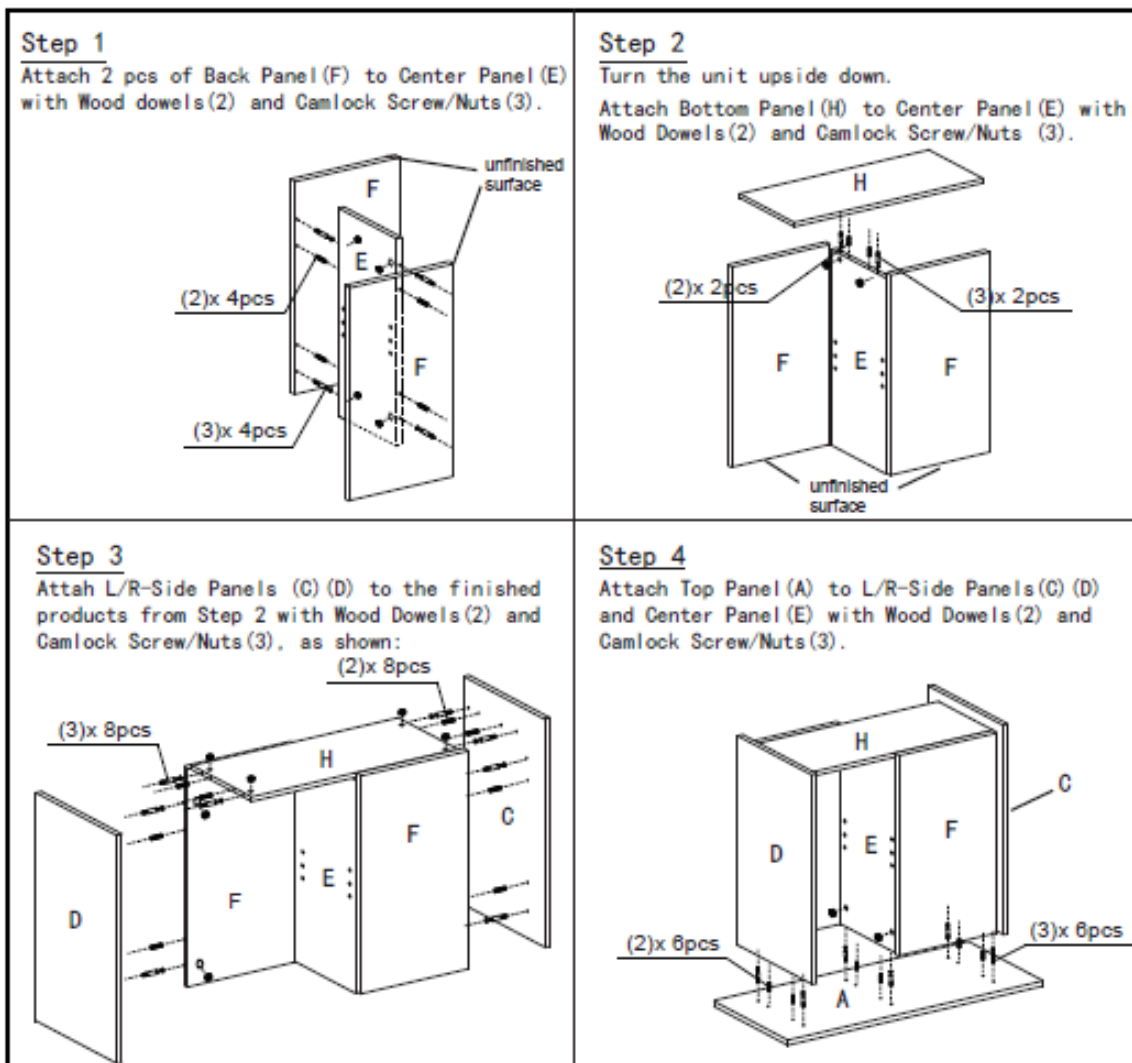

Step 5
Install Pull Knob(5), Stopper (7), Gaster(8) to Door Panel (G).

Step 6
Attach Door Panel (G) to Center Panel (E) with Door Hinge (6).

Step 7
Install Foldable Top Panel (B) to Fixed Top Panel (A) with Hinge(4).

Step 8

8.1 Insert pin support into the desired holes on Center Panel (E) and R-Side Panel (D). Place Shelf Panels (I) on the Pin Supports.

8.2 Paste protective pads (9) on L/R-Side Panels to prevent the Foldable Top Panel from directly hitting side panels, as shown.

Recommended Maximum Weight

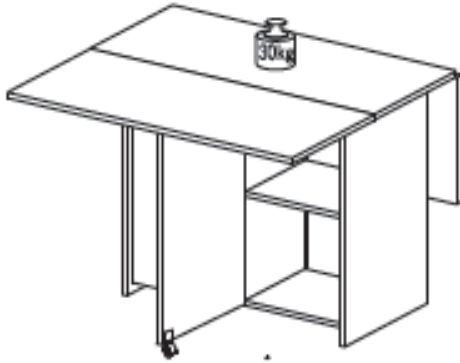

WARNING:

>This unit has been designed to support the maximum loads shown. Exceeding these load limits could cause sagging, instability, product collapse, and/or serious injury.

>DO NOT allow children to climb on unit.

>Put heavier items on lower shelves.

Disposal:

- Dispose of the packaging at your local recycling centre.
- Dispose of the paper and carton separately from plastic bags as your local recycling centre.
- Dispose of the unit at the end of its lifespan at your local authorised household waste recycling centre.