

Wooden Garden Storage Cabinet 10545

Instructions for Use

Please read and retain these instructions for future reference

v001: 14/10/2016

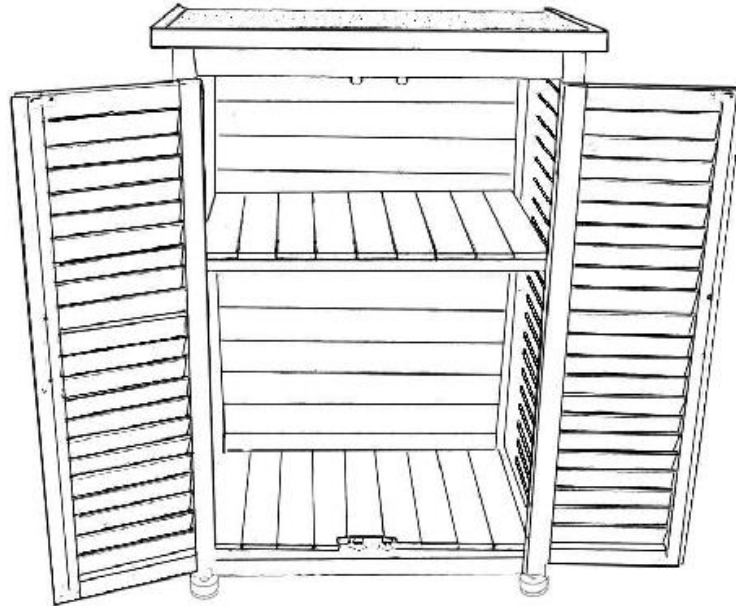

Parts:

A  3.5*40 28 pcs

B  3.5*35 4 pcs

 2 PCS

 4 PCS

 4 PCS

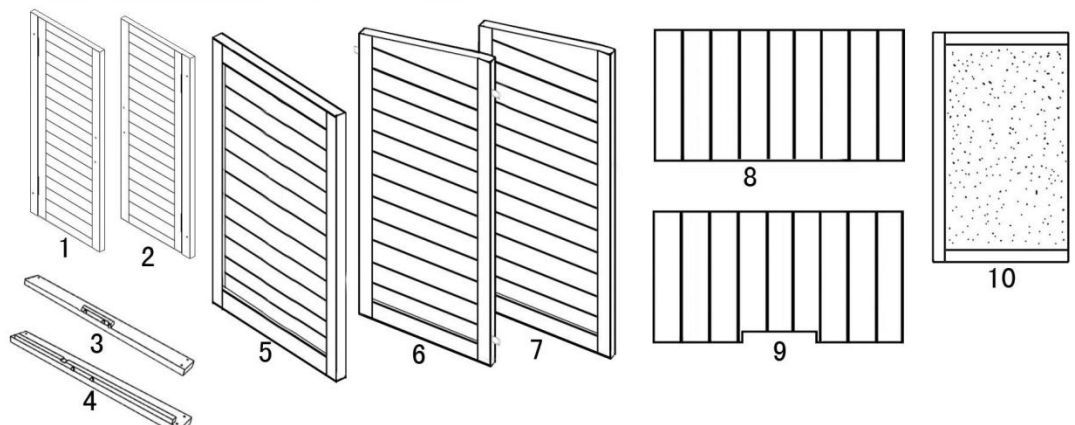

Wooden Garden Storage Cabinet 10545

Instructions for Use

Please read and retain these instructions for future reference

v001: 14/10/2016

Assembly Instructions:

Step 1: Attach the Side Panels parts 6 & 7 to the Back Board part 5 by using 6x A Long Screw.

1x Part 5

1x Part 6

1x Part 7

6x Part A

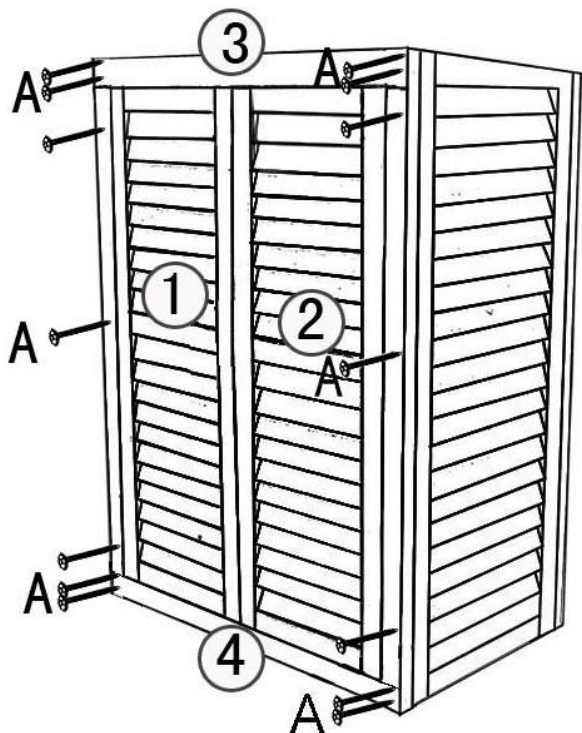
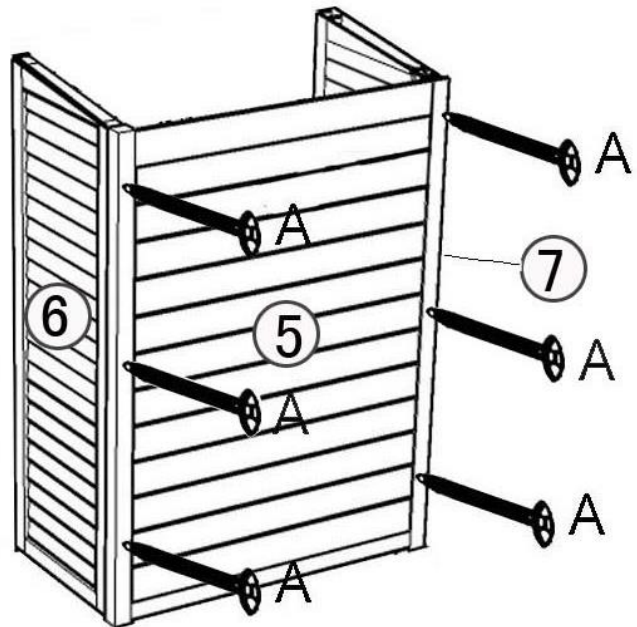

Step 2: Attach the Top Bar Part 3 and the Base Bar Part 4 to the frame by using 8x Part A Long Screw. Next fasten Parts 1 & 2 Left & Right Doors to the frame with 6xPart A Long Screw, ensuring that the slats are facing down.

1x Part 1

1x Part 2

1x Part 3

1x Part 4

14x Part A

Wooden Garden Storage Cabinet 10545

Instructions for Use

Please read and retain these instructions for future reference

v001: 14/10/2016

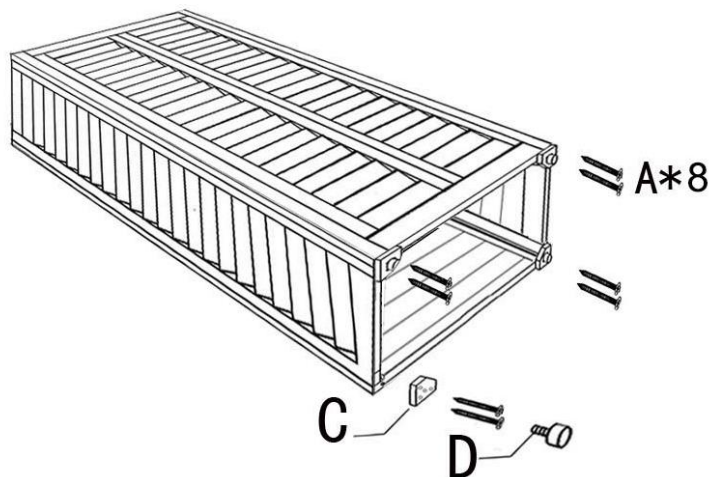

Step 3: Secure the Foot Brackets Part C to each corner of the unit using 8x Part A Long Screw.

Screw in the adjustable Feet Part D to the middle of the Foot Bracket Part C.

Step 4: Place the Top Panel on the completed frame by using 4x Part B Small Screw.

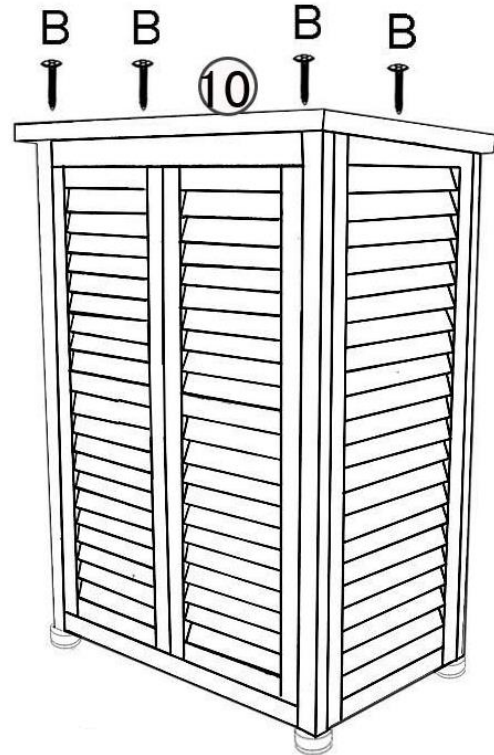

Wooden Garden Storage Cabinet 10545

Instructions for Use

Please read and retain these instructions for future reference

v001: 14/10/2016

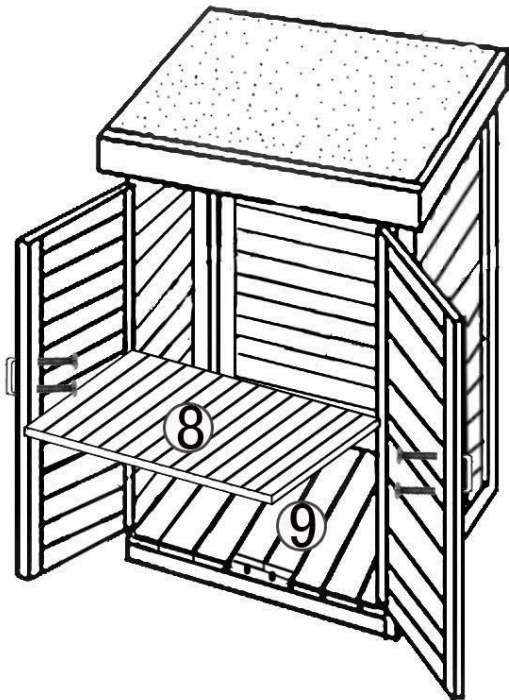

Step 5: Slot the Base Panel Part 9 into the bottom of the frame. Next slot the Middle Shelf in the centre of the frame.

Attach the Handles on to each Door with the screws provided.

Step 6: Place the completed unit in position and adjust the Feet Part D to ensure that the unit is level and stable.

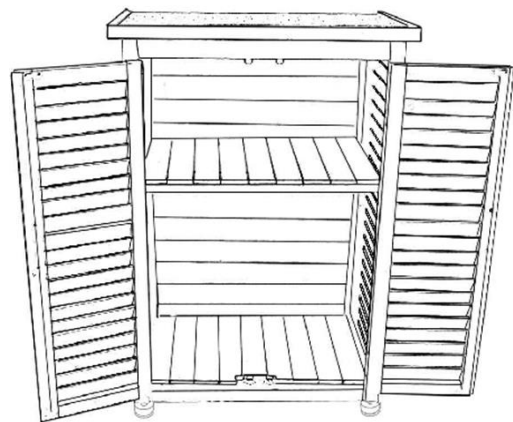

WARNING:

- Place on a level surface

CLEANING INSTRUCTIONS: Use a soft brush.

DISPOSAL:

- Dispose of all packaging, paper, cartons and plastic, plastic bags in accordance with your local recycling regulations.
- At the end of the product's lifespan please dispose of it at an authorised household waste recycling centre.