

# 160L Wheeled Collection Bag with Rake 10546 Instructions for Use

Please read and retain these instructions for future reference

v002:05/12/16/2016

## PARTS

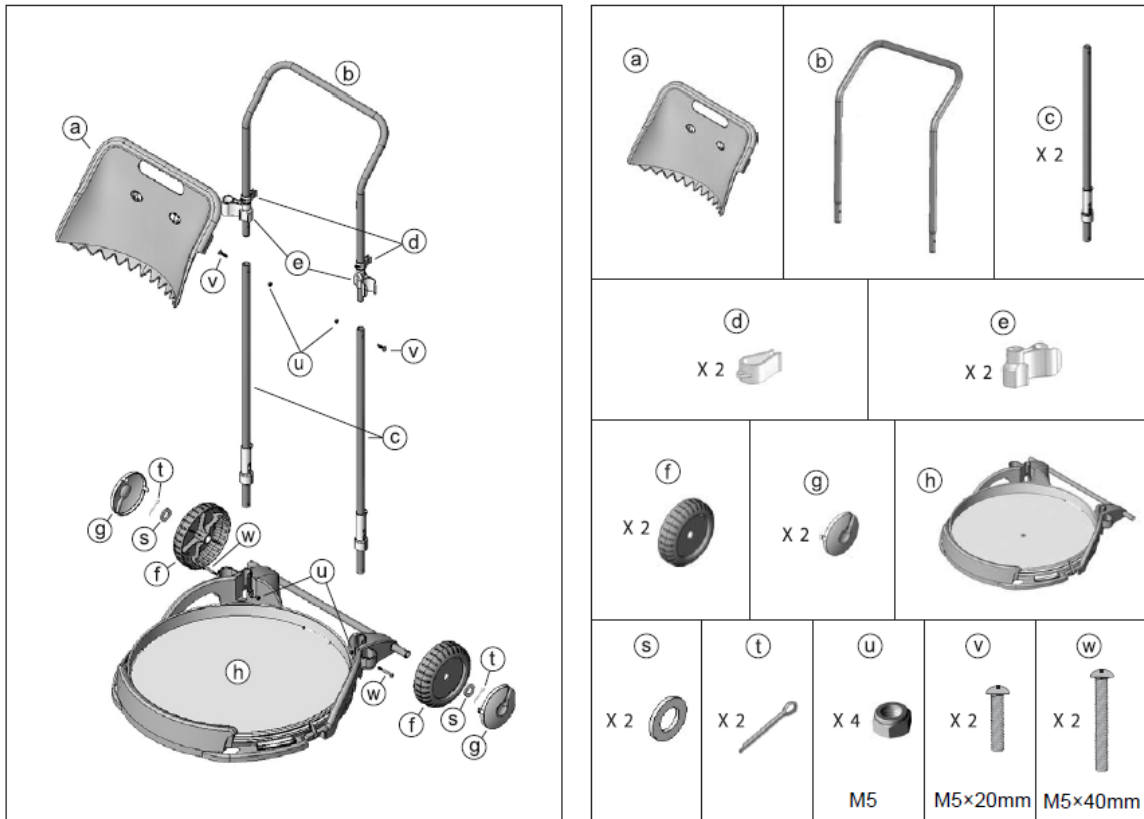

Max. weight: 15kg

## ASSEMBLY:

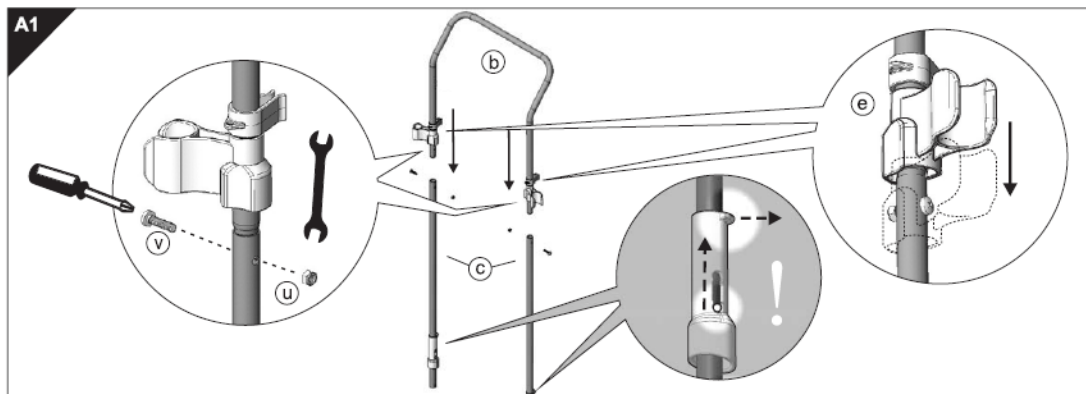

1. Attach part b (the top handle) to part c (the lower poles) using the screws and nuts, parts u and v.
2. Slide part e (the handle clip) down over the screws that have just been inserted.

# 160L Wheeled Collection Bag with Rake 10546 Instructions for Use

Please read and retain these instructions for future reference

v002:05/12/16/2016

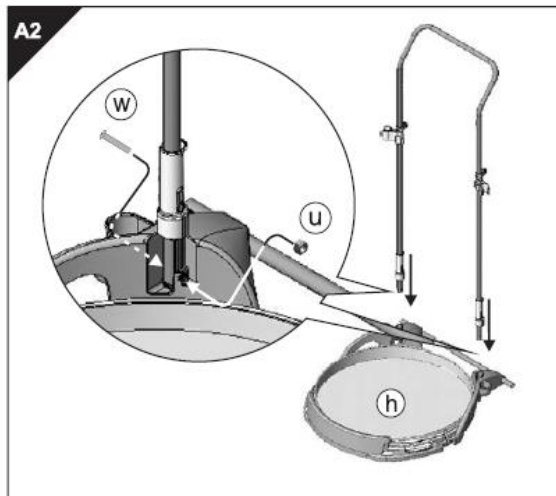

3. Insert the handle poles into the frame base attached to part h and secure using the screws and nuts, parts w and u.

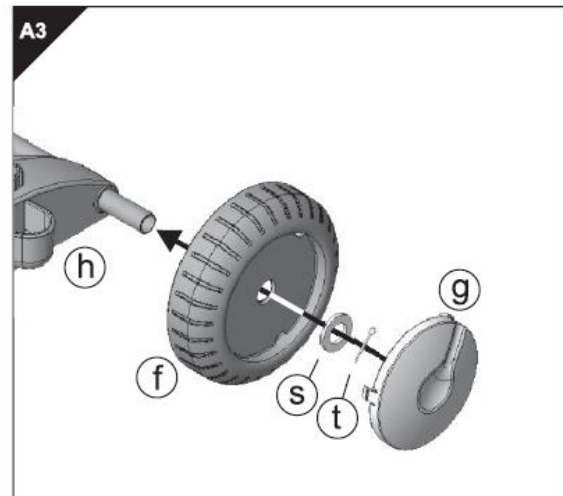

4. Place the wheel part f onto the axle on part h. Slide the washer (part s) over the axle and attach by inserting the split pin (part t) into the hole on the axle.

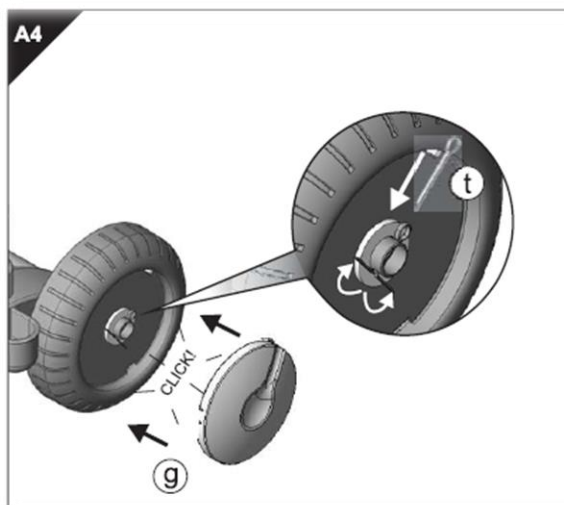

5. Bend the ends of the split pin around the axle, and then place the wheel hub (part g) into the wheel ensuring that this is clicked into place.



6. Attach the hand scoop (part a) to the frame (part b) by pressing down and making sure that the clips are clicked into place.

# 160L Wheeled Collection Bag with Rake 10546 Instructions for Use

Please read and retain these instructions for future reference

v002:05/12/16/2016

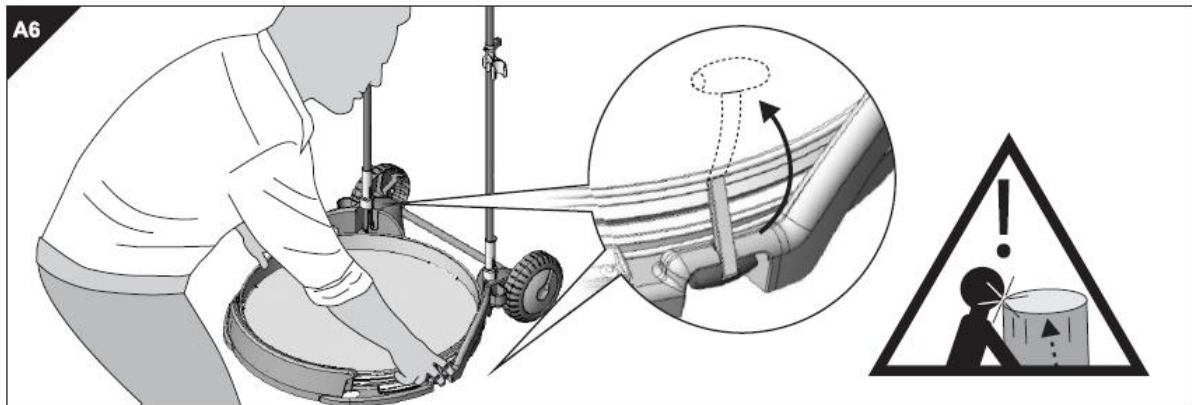

7. Expand the collection bag by unclipping the toggle on each side of the bag; be careful as this can expand quickly.

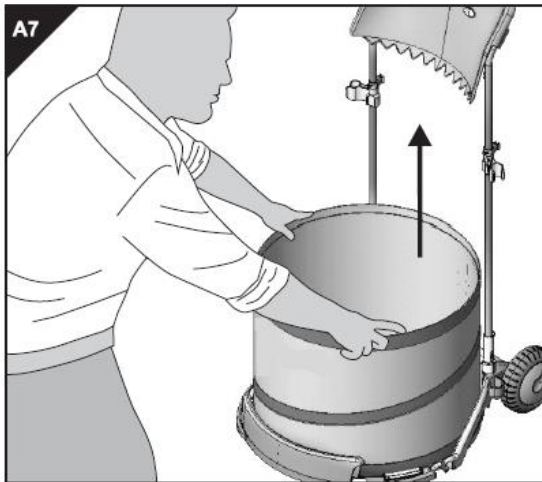

8. When the collection bag is expanded please ensure that this is placed behind the hand scoop.

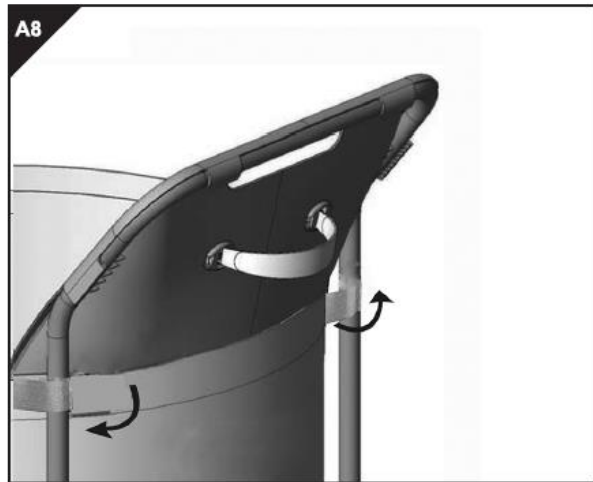

9. Use the hook and loop on the collection bag and secure round the frame.

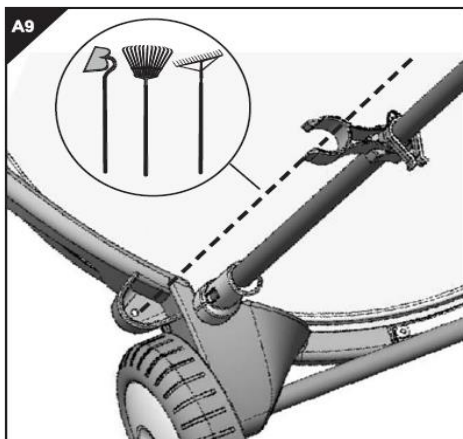

# 160L Wheeled Collection Bag with Rake 10546 Instructions for Use

Please read and retain these instructions for future reference

v002:05/12/16/2016

## HOW TO USE

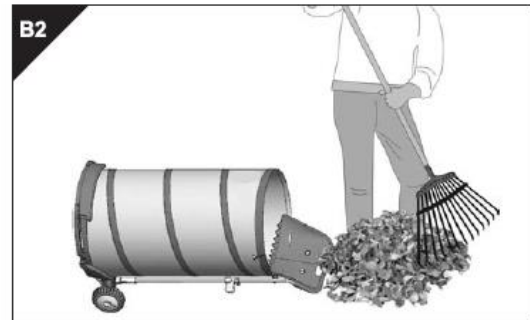
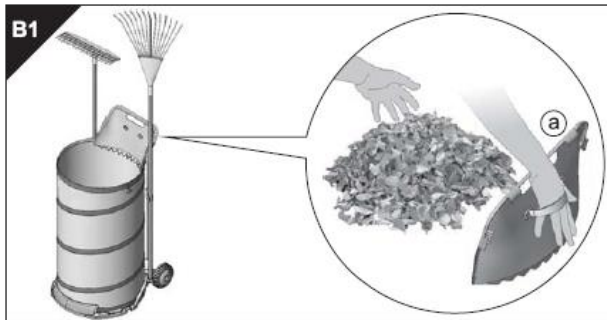

## HOW TO STORE

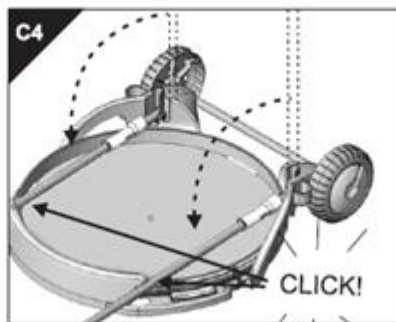
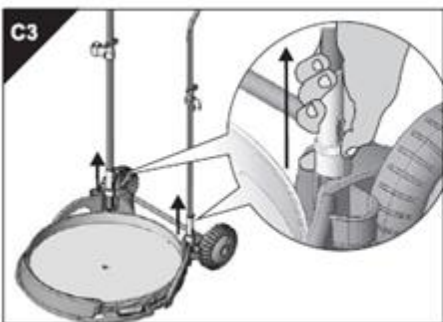
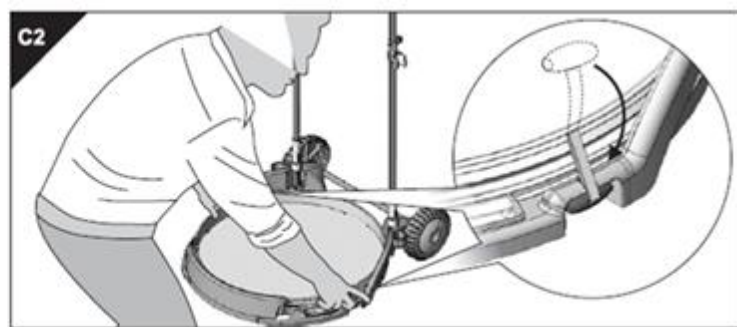

1. To collapse the collection bag, undo the hook and loop and the push down on the bag and secure back into place by using the toggles on each side.
2. Push down on the clips that are located on the main frame near the wheels and fold flat and make sure this clicks into place.

### CLEANING:

- Wipe clean only.

### DISPOSAL:

- Dispose of all packaging, paper, cartons and plastic, plastic bags in accordance with your local recycling regulations.
- At the end of the product's lifespan, please dispose of it at an authorised household waste recycling centre.