

Set of 3 Nested Tables 10576

Instructions for Use

Please read and retain these instructions for future reference

v001: 10/11/16

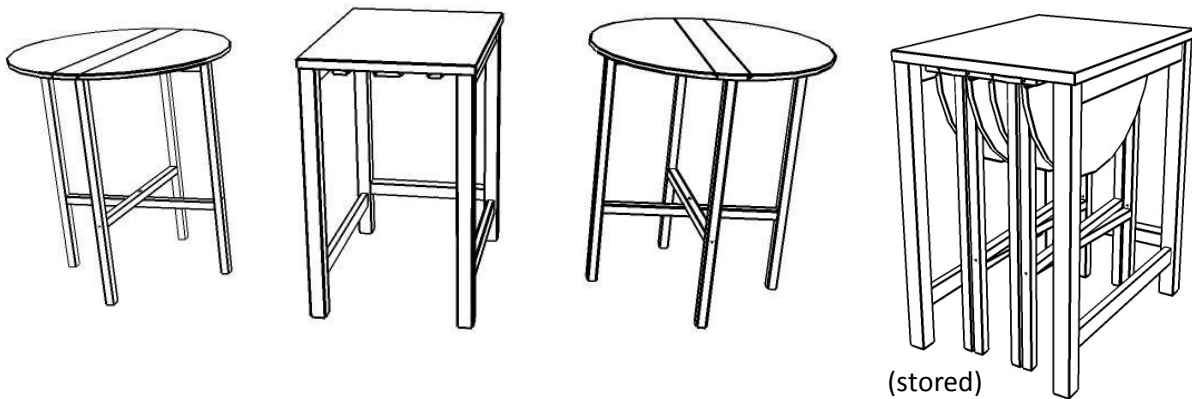

Parts List:

A. Top with wood piece Qty:2 	B. Top Board Qty:2 	C. Top Centre Qty: 2
D. Top Brace Qty: 2 	E. Lower Brace Qty: 2 	F. Leg Qty: 4
G. Leg Qty: 4 	H. Left Side Qty: 1 	I. Lower Cross Bar Qty: 1
J. Upper Cross Bar Qty: 1 	K. Rectangular Top Qty: 1 	L. Right Side Qty: 1

Hardware List:

1. Short Wood Screw Qty: 40 	2. Short Machine Screw Qty: 9 	3. Long Machine Screw Qty: 16
4. Cap Qty: 20 	5. Hinge Qty: 8 	6. Wrench Qty: 1
7. Long Wood Screw Qty: 4 		
8. Lock-1 Qty:1 	9. Lock-2 Qty:1 	10. Eva Pad Qty:12

*Calls cost 7 pence per minute plus your telephone company's network access charge.

Head Office, 11 Bridge Street,
 Bishop's Stortford CM23 2JU
 Tel: 0844 482 4400*
 Fax: 01279 756595
 www.coopersofstortford.co.uk

Coopers
 OF STORTFORD

Assembly Instructions:

To assemble:

Step 1

Lay the Top parts (A), (B), and (C) upside down on a clean, soft surface. Use the Wood Screws (1) to attach the hinges(5) and Lock-1(8) as shown.

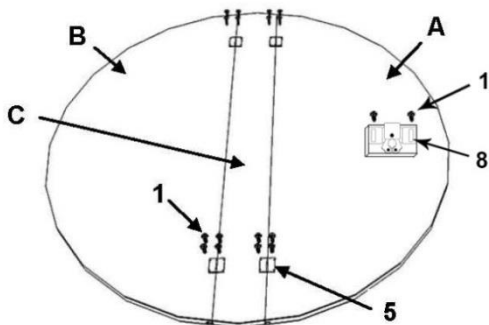

Step 2

Use two Short Machine Screws (2) to attach the Top Brace (D) to the Top Centre (C). Use Wood screws (1) to attach the Lock-2 (9) to Top Brace (D).

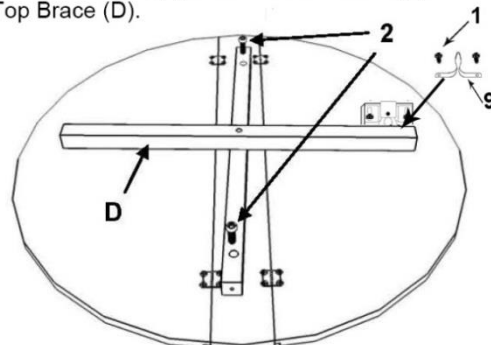

Step 3

Use Long Machine Screws (3) to attach Legs (G) to the fixed part of the Top Brace and Legs (F) to the moving part of the Top Brace.

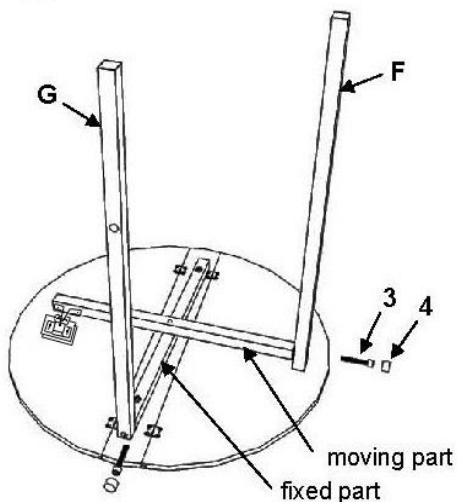

Step 4

Use Long Machine Screws (3) to attach the Lower Brace (E) to Legs (G) and (F). Be sure the Lower Brace is oriented as shown.

Be sure all Screws are tight, and insert Caps (4) in the holes.

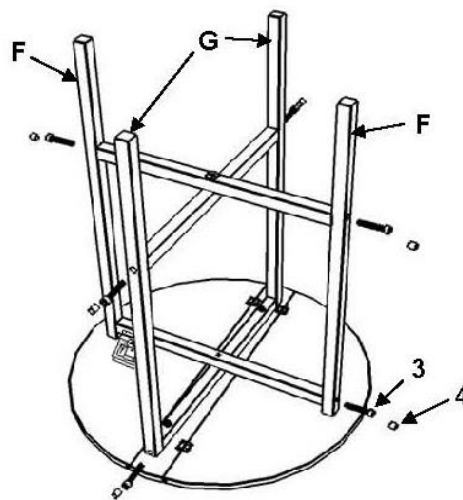

Set of 3 Nested Tables 10576

Instructions for Use

Please read and retain these instructions for future reference

v001: 10/11/16

Step 5

Use the Long Wood Screws (7) to attach the Bars (I) and (J) to the Left Side (H).

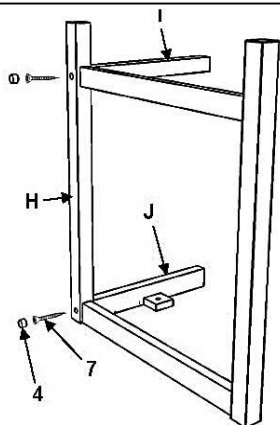

Step 6

Use the Long Wood Screws (7) to attach the Right Side (L) to the Bars (I) and (J).

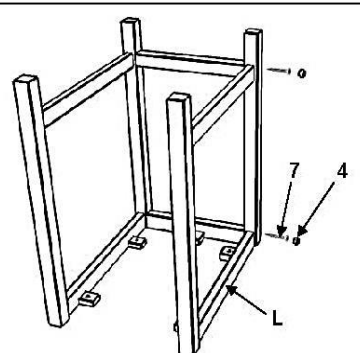

Step 7

Use Short Machine Screws (2) to attach the leg frame from Step 6 to the Rectangular Top (K).

Be sure all screws are tight. Insert Caps (4) in the holes.

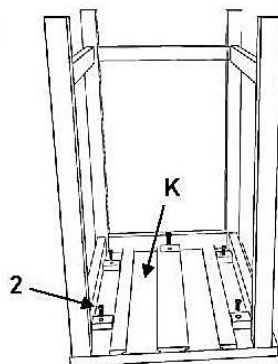

CAUTIONS:

- Adult assembly required. Additional tools required: Phillips screwdriver.
- There are EVA pads included to affix to the bottom of the legs, to help keep the tables from scratching the floor.
- Do not place directly in front of or near sources of heat.
- Periodically check that all fixings are secure and tighten if necessary.
- Do not sit on the table top.
- Do not place hot items directly on the table surface, use coasters to avoid staining.
- Max weight: 10 kg.
- For storage, the two round tables can fold down to store inside the rectangular table

CLEANING INSTRUCTIONS:

- Clean with a dry cloth or duster.

DISPOSAL:

- Dispose of all packaging, paper, cartons and plastic, plastic bags in accordance with your local recycling regulations.
- At the end of the product's lifespan please dispose of it at an authorised household waste recycling centre.

Head Office, 11 Bridge Street,
Bishop's Stortford CM23 2JU
Tel: 0844 482 4400*
Fax: 01279 756595
www.coopersofstortford.co.uk

Coopers
OF STORTFORD

*Calls cost 7 pence per minute plus your telephone company's network access charge.