

## 2 Seater Bench with Coffee Table 10607 Instructions for Use

Please read and retain these instructions for future reference

v001: 08/11/16

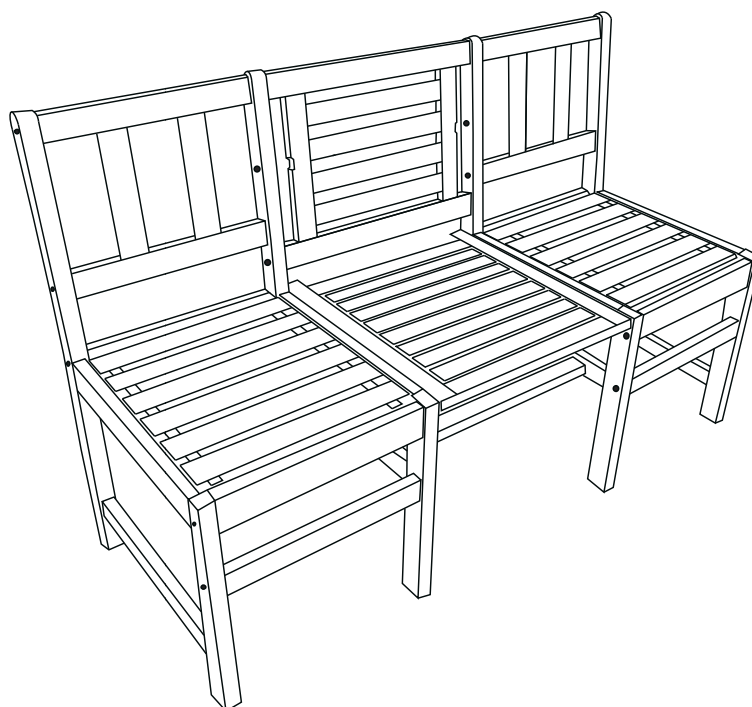

\*Calls cost 7 pence per minute plus your telephone company's network access charge.

Head Office, 11 Bridge Street,  
Bishop's Stortford CM23 2JU  
Tel: 0844 482 4400\*  
Fax: 01279 756595  
[www.coopersofstortford.co.uk](http://www.coopersofstortford.co.uk)















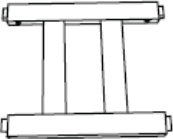

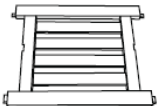

**Coopers**  
OF STORTFORD

# 2 Seater Bench with Coffee Table 10607 Instructions for Use

Please read and retain these instructions for future reference

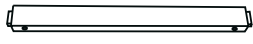
v001: 08/11/16

## Parts list:

- |    |   |                                      |    |  |                 |
|----|---|--------------------------------------|----|--|-----------------|
| A. |    | Outside panel x2                     | 1. |    | Large screw x10 |
| B. |    | Inside panel x2                      | 2. |    | Large Bolt x16  |
| C. |    | Backrest x2                          | 3. |    | Bolt nut x16    |
| D. |   | Middle seat x1<br>(or table)         | 4. |    | Small bolt x2   |
| E. |  | Middle Backrest x1                   | 5. |  | Medium Screw x2 |
| F. |  | Left & Right seat x2                 | 6. |  | Small Screw x3  |
| G. |  | Seat brace x4<br>D 38.5 x W 6 cm     | 7. |  | Allen Key x2    |
| H. |  | Connection bar x1<br>D 48.5 x W 4 cm |    |  |                 |
| I. |  | Connection bar x1<br>D 49.5 x W 4 cm |    |  |                 |
| K. |  | Front bar x2<br>D 38.5 x W 4 cm      |    |  |                 |
| L. |  | Table stand bar x1                   |    |  |                 |

Head Office, 11 Bridge Street,  
Bishop's Stortford CM23 2JU  
Tel: 0844 482 4400\*  
Fax: 01279 756595  
www.coopersofstortford.co.uk

# Coopers

# 2 Seater Bench with Coffee Table 10607 Instructions for Use

Please read and retain these instructions for future reference

v001: 08/11/16

## Assembly Instructions:

### Step 1

Assemble each chair separately.

Attach the Outside Panel (Part A) to the Backrest (Part C), and the Seat Brace (Part G), Front Bar (Part K), using Large Screw (1) and the Large Bolts (2) together with Bolt nuts (3).

Repeat the above step to attach the Inside panel (Part B).

Repeat to assemble the other chair.

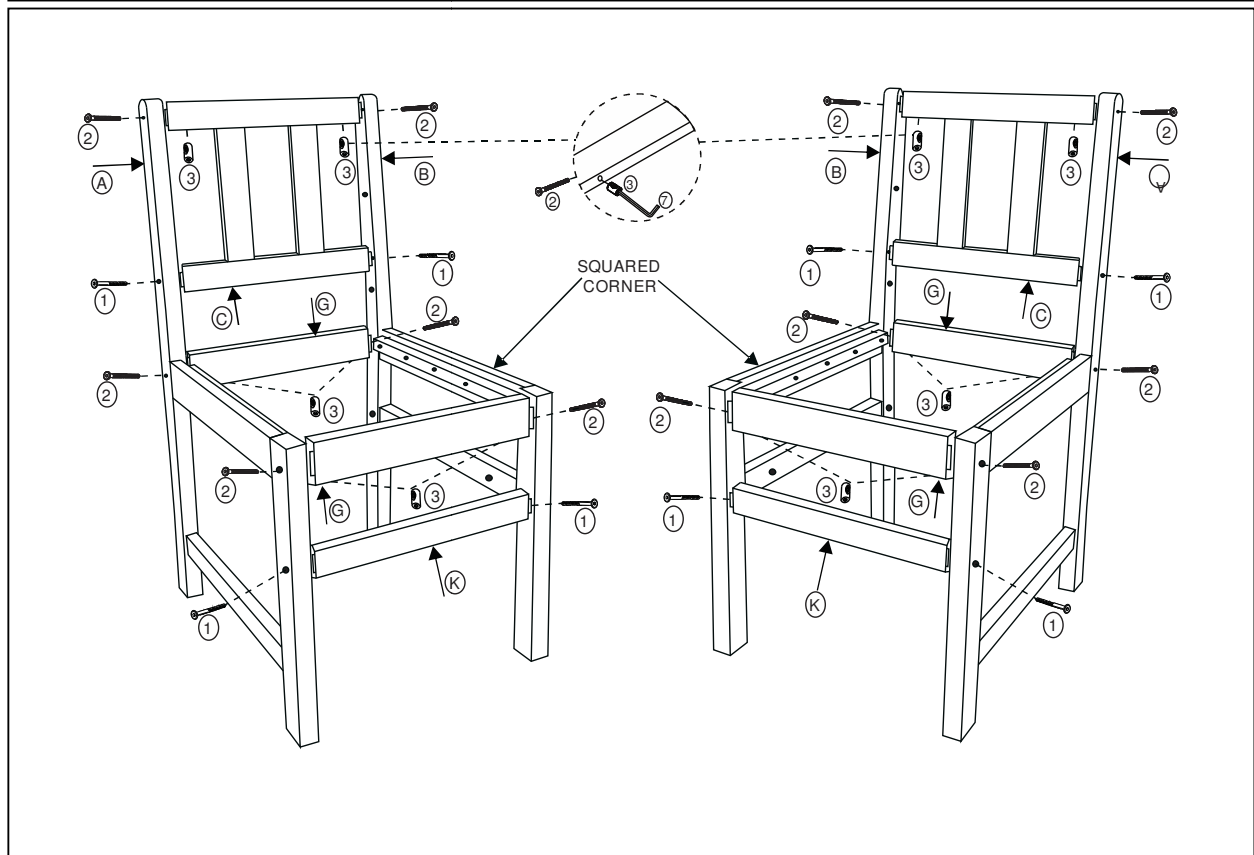

\*Calls cost 7 pence per minute plus your telephone company's network access charge.

Head Office, 11 Bridge Street,  
Bishop's Stortford CM23 2JU  
Tel: 0844 482 4400\*  
Fax: 01279 756595  
www.coopersofstortford.co.uk

**Coopers**  
OF STORTFORD

# 2 Seater Bench with Coffee Table 10607 Instructions for Use

Please read and retain these instructions for future reference

v001: 08/11/16

## Step 2

Connect the Middle Backrest (Part E) to the Inside Panels (Part B), using Medium Screw (5) and Large Screw (1).

At the same time, attached the Connection bars (Part H) and (Part I) to the Inside Panels (Part B), using Large Bolts (2) together with Bolt nuts (3).

Put the Seats (Part F) to their position.

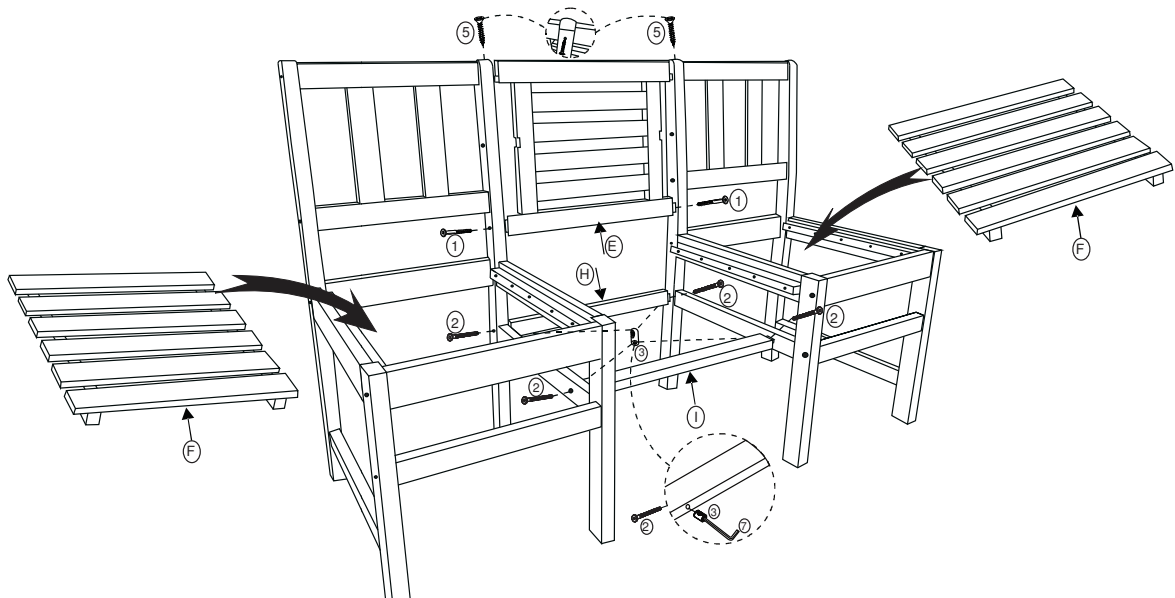

## Step 3

Attach the Table Stand Bar (Part L) to the Middle Seat (Part D), using Small Screws (6).

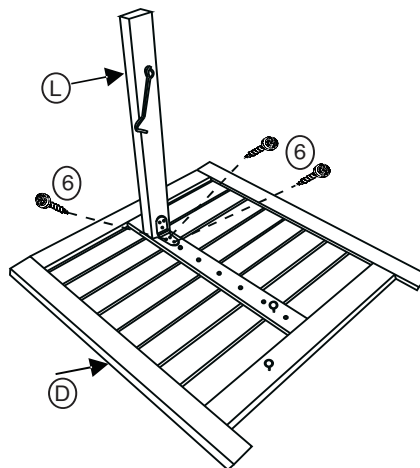

\*Calls cost 7 pence per minute plus your telephone company's network access charge.

Head Office, 11 Bridge Street,  
Bishop's Stortford CM23 2JU  
Tel: 0844 482 4400\*  
Fax: 01279 756595

[www.coopersofstortford.co.uk](http://www.coopersofstortford.co.uk)

**Coopers**  
OF STORTFORD

## 2 Seater Bench with Coffee Table 10607 Instructions for Use

Please read and retain these instructions for future reference

v001: 08/11/16

### Step 4

Attached the table (Part D) to the Middle Backrest Part E), using Small Bolts (4).

Fasten the hook on the Table stand bar (Part L) to the connection bar (Part I) to make sure the table is secured before using.

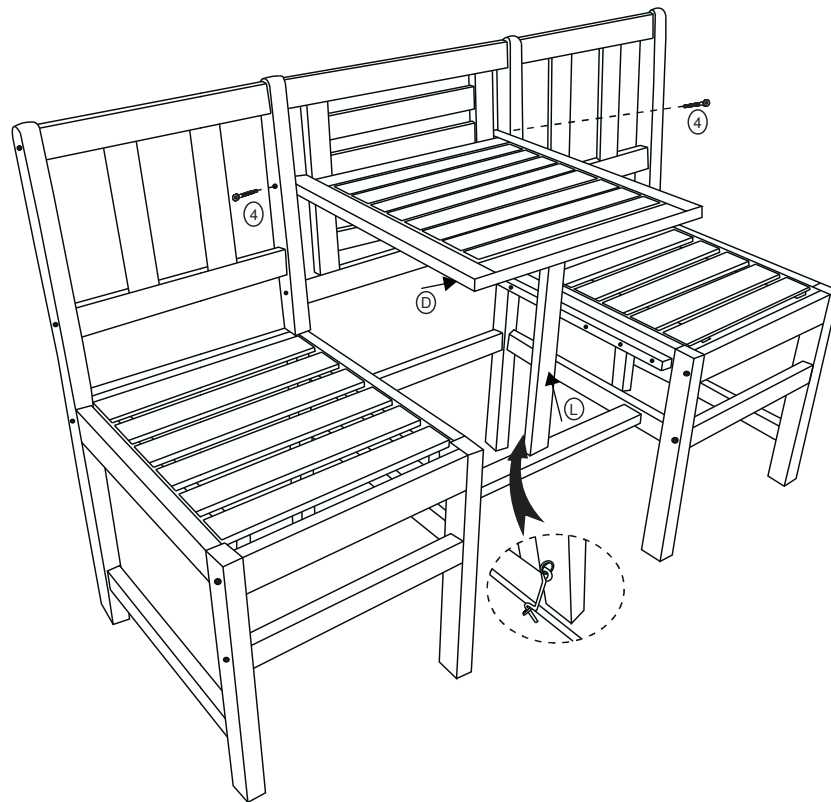

\*Calls cost 7 pence per minute plus your telephone company's network access charge.

Head Office, 11 Bridge Street,  
Bishop's Stortford CM23 2JU  
Tel: 0844 482 4400\*  
Fax: 01279 756595  
www.coopersofstortford.co.uk

**Coopers**  
OF STORTFORD

## 2 Seater Bench with Coffee Table 10607 Instructions for Use

Please read and retain these instructions for future reference

v001: 08/11/16

### Step 5

If do not want to use table, pull out 2 Small Bolts (4) and move it to become a seat.

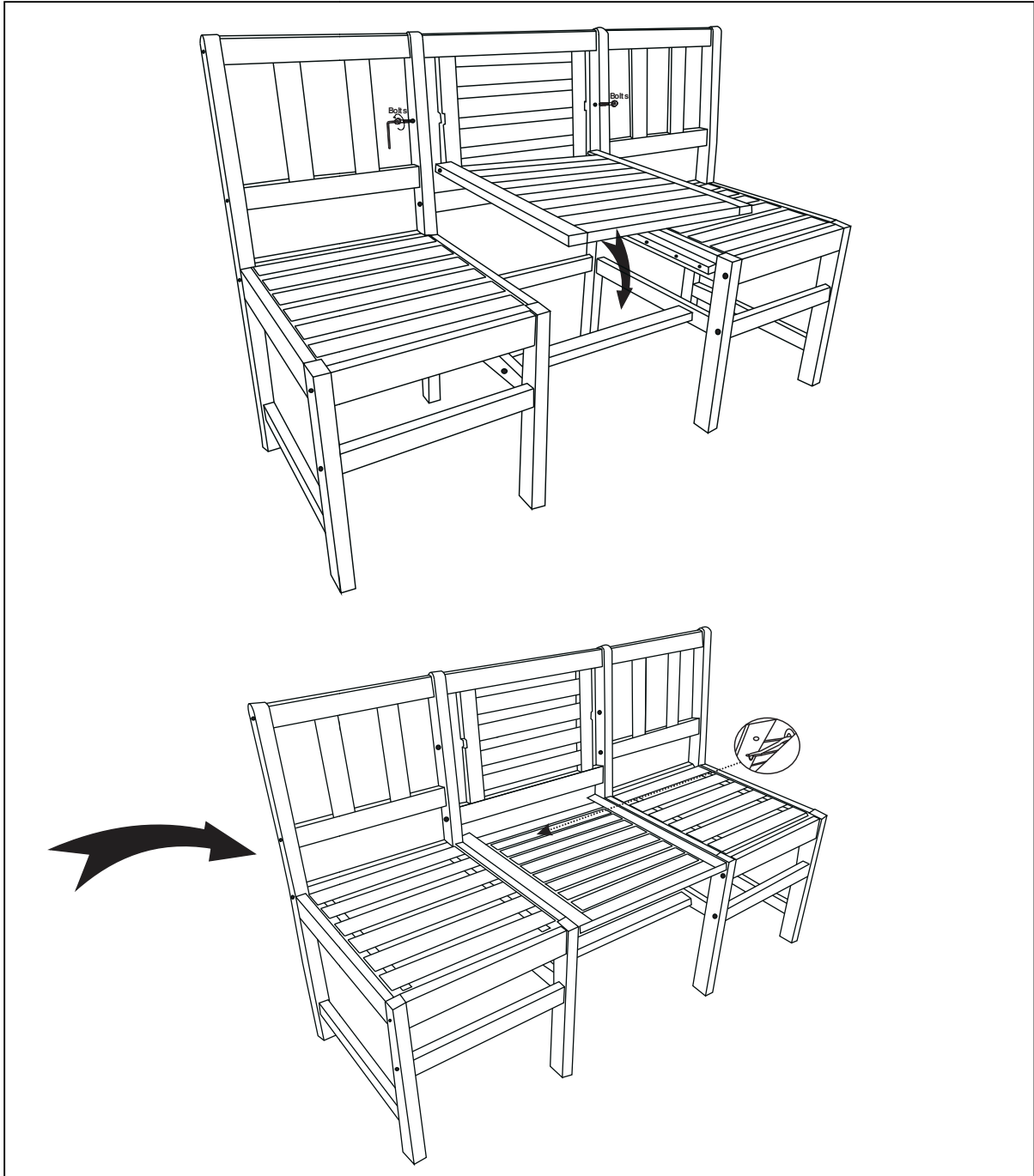

Head Office, 11 Bridge Street,  
Bishop's Stortford CM23 2JU  
Tel: 0844 482 4400\*  
Fax: 01279 756595  
www.coopersofstortford.co.uk

**Coopers**  
OF STORTFORD

\*Calls cost 7 pence per minute plus your telephone company's network access charge.

# 2 Seater Bench with Coffee Table 10607 Instructions for Use

Please read and retain these instructions for future reference

v001: 08/11/16

## WARNINGS / CAUTIONS:

- Do NOT use on an uneven surface.
- When the Bench is NOT in use, please cover or store in a dry garage/shed.
- Take care when lifting this item.
- Maximum Weight is 200KG

## CLEANING INSTRUCTIONS:

- Wipe Clean with a soft brush.

## DISPOSAL:

- Dispose of all packaging, paper, cartons and plastic, plastic bags in accordance with your local recycling regulations.
- At the end of the product's lifespan please dispose of it at an authorised household waste recycling centre.

\*Calls cost 7 pence per minute plus your telephone company's network access charge.

Head Office, 11 Bridge Street,  
Bishop's Stortford CM23 2JU  
Tel: 0844 482 4400\*  
Fax: 01279 756595  
[www.coopersofstortford.co.uk](http://www.coopersofstortford.co.uk)

**Coopers**  
OF STORTFORD