

15 Bin Tool Storage 10926

Instructions for Use

Please read and retain these instructions for future reference

v001: 25/07/17

1

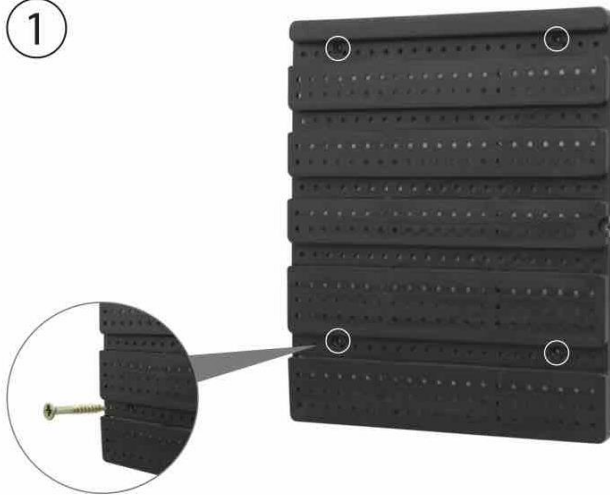

DIMENSIONS

323mmW x 385mm (H)

2

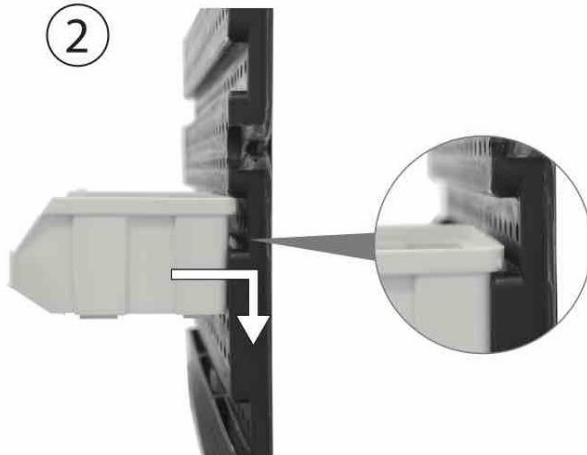

CUSTOMER NOTICE

THIS PRODUCT IS DESIGNED FOR DOMESTIC USE ONLY. EACH STORAGE BIN HAS A MAXIMUM WEIGHT LOADING OF 500G. PLEASE ENSURE THE BACK PANELS ARE SECURELY ATTACHED USING SUITABLE WALL FIXINGS DEPENDING ON THE CONSTRUCTION OF THE WALL YOU ARE ADHERING TO.

Wall fixings are not included.

3



DISPOSAL

- Dispose of all packaging, paper, cartons and plastic, plastic bags in accordance with your local recycling regulations.
- At the end of the product's lifespan please dispose of it at an authorised household WEEE waste recycling centre.