





Parts

NO	STYLE	Q'TY	SPEC
A		4	3.5x30mm
B		10	M6x35mm
C		4	M6x50mm
D		2	

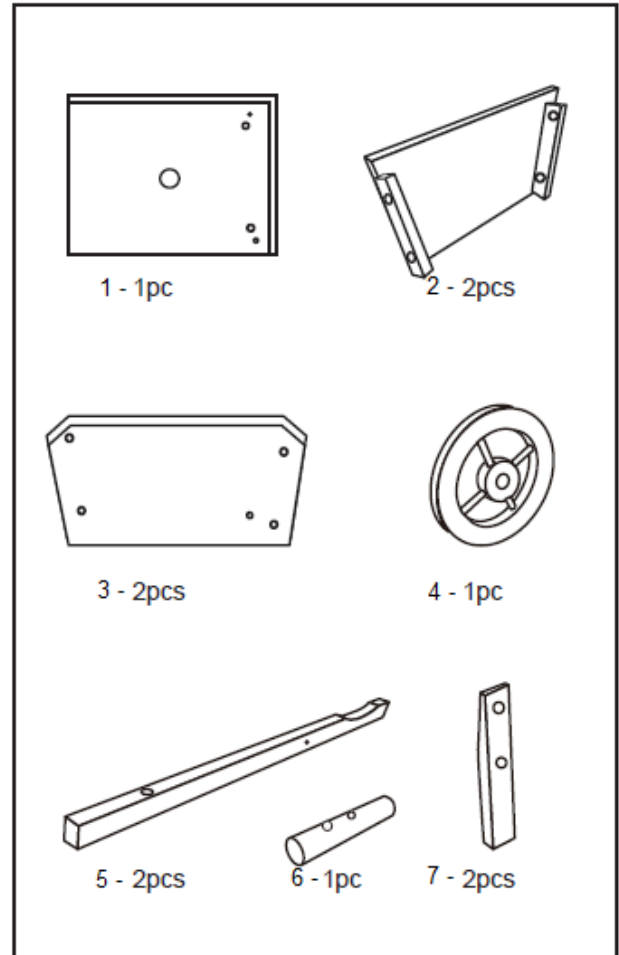

IMPORTANT:

Part no. 2 the parts are NOT identical. The part with pre-drilled holes underneath is the front piece which attaches to part no. 3.

ASSEMBLY INSTRUCTIONS

Step 1

Using bolts part B x4 on each side where shown, connect parts 2 and 3.

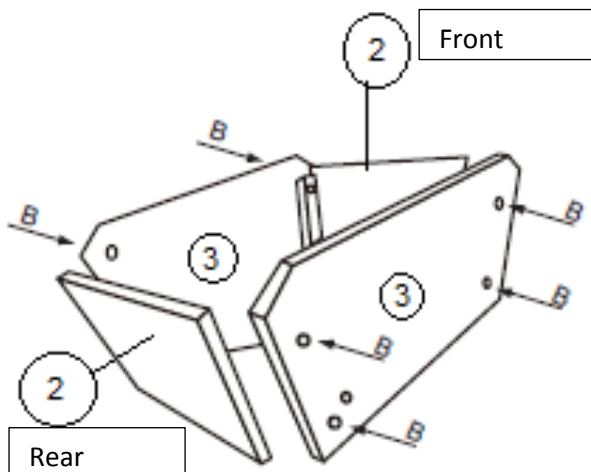

Step 2

Turn upside down and connect part 1 to the assembly using 2x screws A.

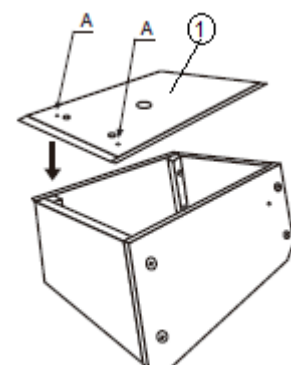

Step 3

Fit parts 5 using 2x bolts C.

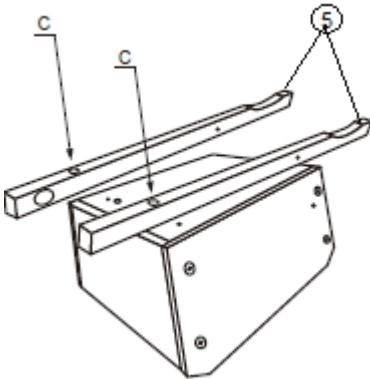

Step 4

Slot in assembled wheel as shown.

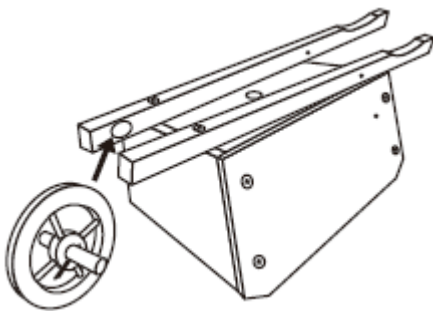

Assemble wheel

Attach 2x parts 6 to the wheel (part 4) using 2x pins D.

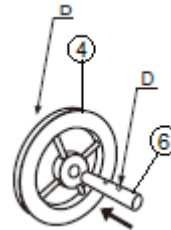

Step 5

Turn right way up. Fit parts 5 to the wheel on either side using 2 x screw A. Fit part 7 to part 5 on either side using screw C and to part 3 using 2x bolts B.

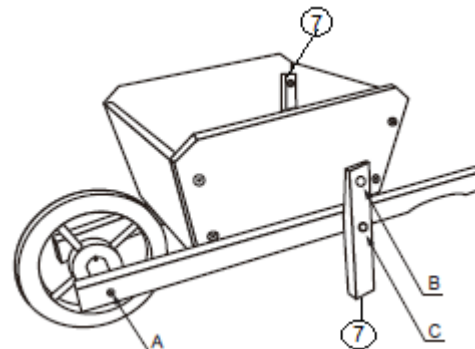

DISPOSAL

- Dispose of all packaging, paper, cartons, plastic and plastic bags in accordance with your local recycling regulations.
- At the end of the product's lifespan please dispose of it at an authorised household WEEE waste recycling centre.