



Battery Charger:

Voltage: 100 -240V a.c.

Frequency: 50-60Hz

Current: 0.2A

Output: 12.6V d.c. 0.5A

Battery Pack: 11.1V d.c.; 1500mA

COOPERS OF STORTFORD

UK Head Office, 11 Bridge Street, Bishop's Stortford, CM23 2JU

Tel: 0844 4824400*, Fax: 01279 756595

www.coopersofstortford.co.uk

EU address: D.S.B. LD, 160 Bd. de Fourmies, 59100 Roubaix, France

Tel: (+44) 1279 701269

*UK Calls cost around 7 pence per minute plus your telephone company's network access.

Please check with your telephone supplier.

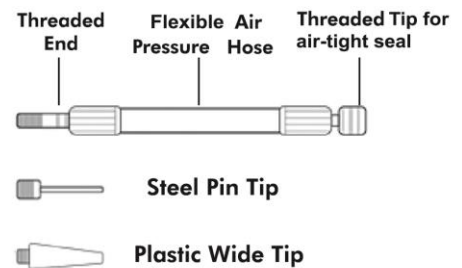
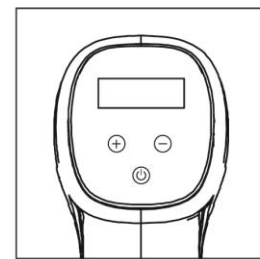
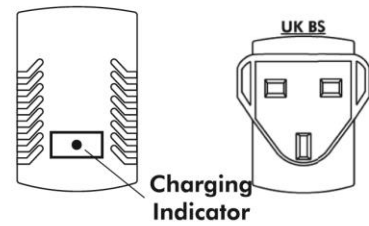
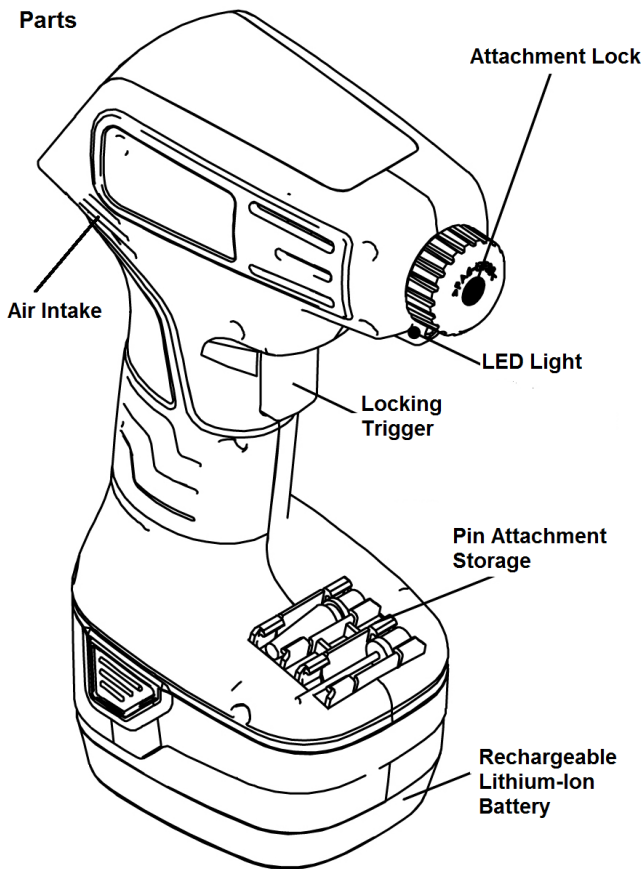

Using Air Rhino

Air Rhino can be used with either the included rechargeable battery pack or DC car adapter.

Charging the Air Rhino

Important! Charge for at least 3 hours before first use.

Do NOT store battery inside unit when not in use.

1. Remove the battery by pressing locking tabs in and pulling it out (See Fig 1).
2. Plug the AC charger into a wall socket. Then connect to the AC charger port on the battery (See Fig 2).
3. Always connect to a domestic indoor mains wall socket when using the AC charger.
4. When LED on charger changes from red to green, charging is finished. This may take up to 3 hours (See Fig 3). Unit should run for approximately 15 minutes per charge.

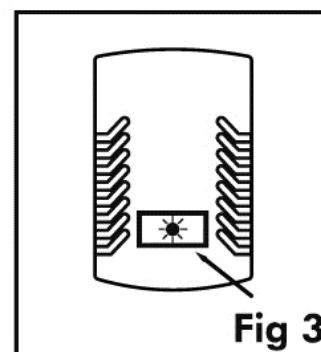
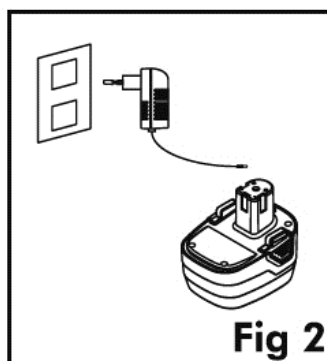
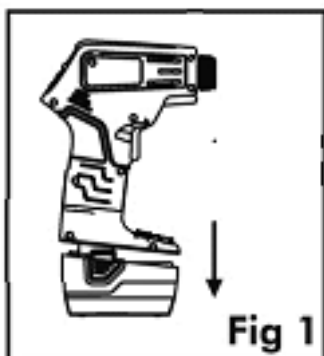

Note: We recommend not charging the battery for more than 5 hours.

NOTE

1. The typical run-time will vary depending on the battery level, pressure load during use, and the operating conditions.
2. High-pressure loading, or excessive back pressure will result in a shorter run-time than indicated.
3. Cold temperature conditions will reduce battery run-time. We recommend using the DC Car Adapter during cold temperature conditions.

Using the 12V Car Adapter

1. Unravel cord before use.
NOTE: Be sure the cord runs through the hole at the base of the pack.
2. If battery is installed, remove from air compressor by pressing locking tabs in and pulling out (See Fig 4).
3. Slide the 12V DC car adapter pack into the air compressor until you hear a click (See Fig 5).
4. Connect the adapter into the DC socket in your car (See Fig 6). When ready to use, power car on. Always operate vehicle outdoors.

COOPERS
OF STORTFORD

UK Head Office, 11 Bridge Street, Bishop's Stortford, CM23 2JU

Tel: 0844 4824400*, Fax: 01279 756595

www.coopersofstortford.co.uk

EU address: D.S.B. LD, 160 Bd. de Fourmies, 59100 Roubaix, France

Tel: (+44) 1279 701269

*UK Calls cost around 7 pence per minute plus your telephone company's network access.

Please check with your telephone supplier.

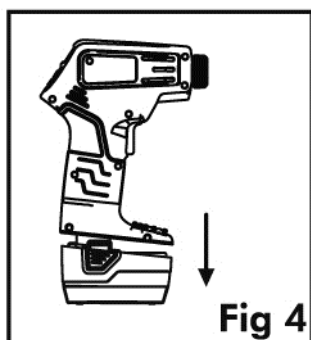

Fig 4

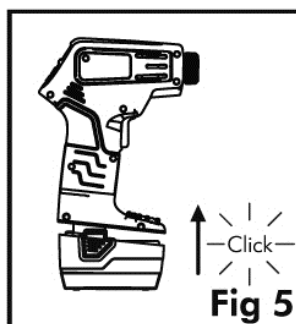

Fig 5

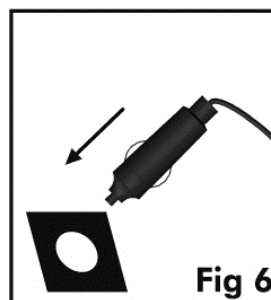

Fig 6

Inflating Instructions

INFLATING TYRES

Loosen the attachment lock approximately 3 rotations counter-clockwise (See Fig 7). Do not remove lock completely.

IMPORTANT: Insert the air hose with threaded end into the attachment lock. Press in firmly while screwing in clockwise until it can go no further (See Fig 8).

Tighten attachment lock clockwise until hand-tight.

Press the Power button below the LCD display to turn on (See Fig 9).

NOTE: After 30 seconds of inactivity, the digital tyre gauge will turn off automatically to conserve energy.

To choose desired pressure format (PSI, BAR, KPA) press the power button continuously until desired format displays.

Screw the threaded connector onto tyre's valve stem quickly. For tyres with air taps the clamp can be used to secure in place.

When connected, the gauge will show current tyre pressure.

Press "+" or "-" to set desired pressure level. Once set, wait a few seconds until current tyre pressure displays.

NOTE: Always check and follow the manufacturer's recommended pressure, usually located on the door jamb of your vehicle.

Air Rhino will begin to inflate the tyre to the set pressure level, and shut off automatically when reached.

When done, press the trigger once to turn off.

Remove the thread connector from the tyre quickly, and replace valve stem cap on tyre, if required.



Fig 7

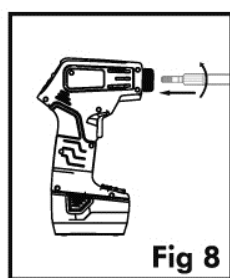

Fig 8

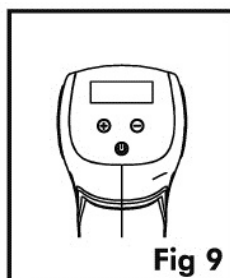

Fig 9

WARNING: Connector may be hot. Use caution when removing.

COOPERS
OF STORTFORD

UK Head Office, 11 Bridge Street, Bishop's Stortford, CM23 2JU

Tel: 0844 4824400*, Fax: 01279 756595

www.coopersofstortford.co.uk

EU address: D.S.B. LD, 160 Bd. de Fourmies, 59100 Roubaix, France

Tel: (+44) 1279 701269

*UK Calls cost around 7 pence per minute plus your telephone company's network access.

Please check with your telephone supplier.

Note: To avoid over-inflation of tyres, please check the recommended tyre pressure in the vehicle's owner's manual. For bicycle tyres, check marking on tyre.

WARNING: The LCD display must turn on before operating the Air Rhino. Please read and understand these instructions provided in the manual prior to operation.

Always turn off the air compressor when not in use to conserve battery power.
Use a separate pressure gauge for more accurate reading.

Inflating items with additional tips

Air Rhino can be used for inflatable toys, air mattresses and sports equipment.
Loosen the attachment lock approximately 3 rotations counter-clockwise (**See Fig 7**). Do not remove lock completely.

IMPORTANT:

Loosen the attachment **Insert the tip into the attachment lock. Press in firmly while screwing in clockwise until it can go no further (See Fig 8).**

Tighten attachment lock clockwise until hand-tight.

Press the Power button below the LCD display to turn on. (**See Fig 9**).

NOTE: After 30 seconds of inactivity, the digital tyre gauge will turn off automatically to conserve energy.

Insert the tip adapter into inflatable object and push trigger.

Allow Air Rhino to run until fully inflated.

Remove tip adapter from the inflated object quickly, and replace valve cover if required.

NOTE: The pressure gauge will only provide an estimated reading.

WARNING:

The LCD display must turn on before operating Air Rhino. Please read, and understand the instruction provide in the manual prior to operation.

Always turn off the air compressor when not in use to conserve battery power.

Use a separate pressure gauge for more accurate reading.

General Safety Measures and precautions that apply to the use of air compressors

Safe operation of the air compressor requires that you read the instructions and safety precautions carefully and follow all instructions before using the air compressor.

FOR HOUSEHOLD USE ONLY

- THE AIR COMPRESSOR IS DESIGNED FOR OCCASIONAL USE. INFLATION OVER A LONG PERIOD WILL OVERHEAT THE AIR COMPRESSOR AND MAY CAUSE DAMAGE.
- **THE AIR COMPRESSOR SHOULD NOT OPERATE FOR MORE THAN 7-8 MINUTES AT A TIME AFTER WHICH IT MUST BE SWITCHED OFF AND SET ASIDE TO COOL FOR AT LEAST 20-30 MINUTES BEFORE RESTARTING. ALWAYS CONNECT TO A DOMESTIC INDOOR MAINS WALL SOCKET WHEN USING THE AC CHARGER.**
- IF THE AIR COMPRESSOR EMITS ABNORMAL SOUND OR OVERHEATS, TURN IT OFF IMMEDIATELY AND LET IT COOL OFF FOR A MINIMUM OF 30 MINUTES.

**COOPERS
OF STORTFORD**

UK Head Office, 11 Bridge Street, Bishop's Stortford, CM23 2JU

Tel: 0844 4824400*, Fax: 01279 756595

www.coopersofstortford.co.uk

EU address: D.S.B. LD, 160 Bd. de Fourmies, 59100 Roubaix, France

Tel: (+44) 1279 701269

*UK Calls cost around 7 pence per minute plus your telephone company's network access.

Please check with your telephone supplier.

- INSPECT AIR COMPRESSOR, AND BATTERIES BEFORE USE. IF CRACKED, BROKEN OR DAMAGED PARTS ARE FOUND, QUALIFIED TECHNICIANS SHOULD REPAIR DAMAGED PARTS.
- INCORRECT USE OF THE AIR COMPRESSOR MAY RESULT IN PERSONAL INJURY AND/OR PROPERTY DAMAGE.
- NEVER EXPOSE THE AIR COMPRESSOR OR BATTERY TO RAIN, FROST OR TEMPERATURE ABOVE 50 °C (122 °F). NEVER CHANGE THE BATTERY IN HUMID OR WET LOCATIONS.
- NEVER USE THE AIR COMPRESSOR NEAR FLAMMABLE FLUIDS OR GASES. MAKE SURE YOUR WORKING AREA IS WELL-LIT.
- PROTECT YOURSELF AGAINST ELECTRIC SHOCK. AVOID PHYSICAL CONTACT WITH GROUNDED SURFACES SUCH AS PIPES, RADIATORS, ELECTRIC STOVES, REFRIGERATORS, ETC.
- NEVER ALLOW CHILDREN TO CONNECT/DISCONNECT THE AIR COMPRESSOR TO/FROM POWER SOURCES. NEVER LEAVE CHILDREN UNATTENDED WITH THE AIR COMPRESSOR AND NEVER ALLOW THEM TO PLAY WITH THE ACCESSORIES.
- NEVER ALLOW ANYONE TO PUMP AIR INTO MOUTH, EARS, NOSE ETC OF PEOPLE, OR ANIMALS. THE AIR COMPRESSOR IS NOT A TOY.
- STORE AIR COMPRESSOR IN A SECURE LOCATION. IF THE AIR COMPRESSOR IS GOING TO BE UNUSED FOR LONG PERIODS OF TIME, IT SHOULD BE STORED IN A DRY PLACE INACCESSIBLE TO CHILDREN.
- REGULARLY CHECK THE CHARGER CORD. NEVER CARRY BY THE CORD AND NEVER PULL THE PLUG OUT OF THE OUTLET BY JERKING THE CORD. MAKE SURE THE CORD IS NOT EXPOSED TO HOT OBJECTS, OIL OR SHARP EDGES.
- KEEP THE AIR COMPRESSOR CLEAN TO MAINTAIN MAXIMUM OUTPUT AND SAFETY. EXAMINE THE PLUG, CHARGER AND CABLE PACK ON A REGULAR BASIS AND HAVE THEM REPAIRED BY A QUALIFIED TECHNICIAN IF THEY ARE DAMAGED.
- UNPLUG THE 12V CAR CIGARETTE LIGHTER ADAPTER FROM THE CIGARETTE LIGHTER SOCKET IN YOUR CAR WHEN THE AIR COMPRESSOR IS NOT IN USE.
- UNPLUG THE AC CHARGER FROM THE BATTERY WHEN THE CHARGER IS NOT IN USE.
- NEVER CHARGE THE BATTERY OUTDOORS. DO NOT OPEN THE BATTERY. PROTECT IT AGAINST IMPACT. THE BATTERY SHOULD BE STORED IN A DRY, FROST-FREE PLACE.
- THE BATTERY AND CHARGER ARE DESIGNED FOR EACH OTHER. ONLY An AIR RHINO APPROVED CHARGER SHOULD BE USED.
- PROTECT THE BATTERY AGAINST HEAT AND FIRE TO PREVENT DANGER DUE TO EXPLOSION!
- DO NOT PLACE THE BATTERY ON A HEATER AND DO NOT EXPOSE IT TO SOLAR RADIATION FOR A PROLONGED PERIOD. EXPOSING THE BATTERY TO TEMPERATURES ABOVE 50 °C (122 °F) WILL DAMAGE THE BATTERY. ALLOW THE BATTERY TO COOL OFF COMPLETELY BEFORE CHARGING.
- DO NOT DIRECTLY CONNECT THE POSITIVE (+) AND NEGATIVE (-) TERMINALS. THIS WILL RESULT IN A SHORT-CIRCUIT CAUSED BY METALLIC ARCING.
- STAY ALERT. ALWAYS PAY ATTENTION TO WHAT YOU ARE DOING WHEN WORKING WITH THE AIR COMPRESSOR, CHARGER AND BATTERY.
- WARNING! FOR YOUR OWN SAFETY, YOU SHOULD ONLY USE ACCESSORIES AND PARTS SPECIFIED IN THE INSTRUCTIONS, OR RECOMMENDED FOR USE BY THE MANUFACTURER. USE OF ACCESSORIES AND OTHER PARTS THAT ARE NOT MENTIONED IN THE INSTRUCTIONS MAY ENTAIL AN INCREASED RISK FOR THE USER OF THE AIR COMPRESSOR.
- TO REDUCE THE RISK OF ELECTRIC SHOCK, DO NOT EXPOSE TO RAIN. STORE INDOORS.
- RISK OF BURSTING – DO NOT ADJUST REGULATOR TO RESULT IN OUTPUT PRESSURE GREATER THAN MARKED MAXIMUM PRESSURE OF ATTACHMENT.

- DO ALLOW UNIT TO COOL DOWN THEN DO REPLACE OR DISCHARGE THE ATTACHMENT. AVOID STORING THE BATTERY PACK INSIDE THE CAR.
- WARNING: RISK OF INJURY – DO NOT DIRECT AIR STREAM AT BODY.



BATTERIES

- Keep batteries away from children and pets.
- Do not mix used and new batteries.
- Remove the batteries if left for long periods.
- Never dispose of batteries in a fire.
- Battery disposal, spent or expired batteries must be properly disposed of and recycled in compliance with local regulations. For detailed information, contact your local authority.
- Follow the battery manufacturer's safety, usage, and disposal instructions.

DISPOSAL

- Coopers of Stortford use recyclable or recycled packaging where possible.
- Please dispose of all packaging, paper, cartons, packaging in accordance with your local recycling regulations.
- Plastics, polybags – Contains the following recyclable plastic.



Code & Symbol		
Type of Plastic	Polypropylene	ABS
Commonly used for	Microwaveable food containers, yoghurt pots, butter tubs, disposable plates and cups	CD's, crisp packets, various flexible packaging, baby bottles, sunglass lenses
Notes	Commonly recycled and collected from household recycling bins (packaging tape itself not recyclable but does not interfere with cardboard)	Not often or widely recycled

- At the end of the product's lifespan please check with your local council authorised household waste recycling centre for disposal.

UK
CA

CE

**COOPERS
OF STORTFORD**

UK Head Office, 11 Bridge Street, Bishop's Stortford, CM23 2JU

Tel: 0844 4824400*, Fax: 01279 756595

www.coopersofstortford.co.uk

EU address: D.S.B. LD, 160 Bd. de Fourmies, 59100 Roubaix, France

Tel: (+44) 1279 701269

*UK Calls cost around 7 pence per minute plus your telephone company's network access.

Please check with your telephone supplier.